

PROJECT TOWEL RAIL 740MM CHROME

60915.02

ELEMENTI

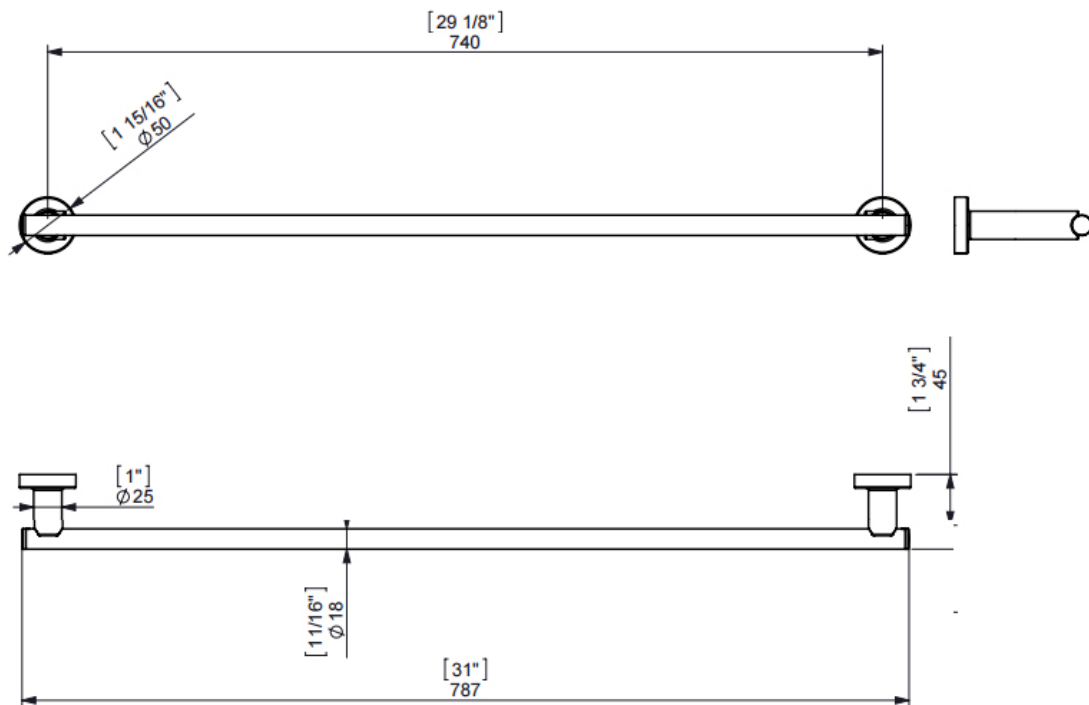

Residential/Light
Commercial

Suitable for Residential/Light Commercial Use (Kitchens,
Bathrooms and Laundries in Motels, Hotels and
Retirement Villages)

10

Guarantee

10 Year Guarantee



Galvanic Plating
Process

CHROME: Galvanic plating process. Covering with 0,3 –
0,4 microns chrome average. Items are tested as per
Norm En 246 with salt spray chamber – 240 hours
(equivalent to 6 years)



Galvanic Plating
Process

BRUSHED NICKEL: Galvanic plating process protected
with transparent lacquer coating (thickness 40-50
microns) . 120 Hours salt spray tested (equivalent to 2
years resistance)





Made in Spain

Project is a sleek, minimalist styled accessory range that will compliment your new bathroom.