

VERONA WALL 1200 1 X DRAWER - DEZIGNA WHITE GLOSS  
POLYMARBLE

ELEMENTI

81440.11

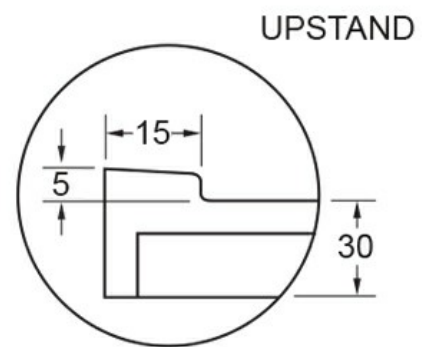
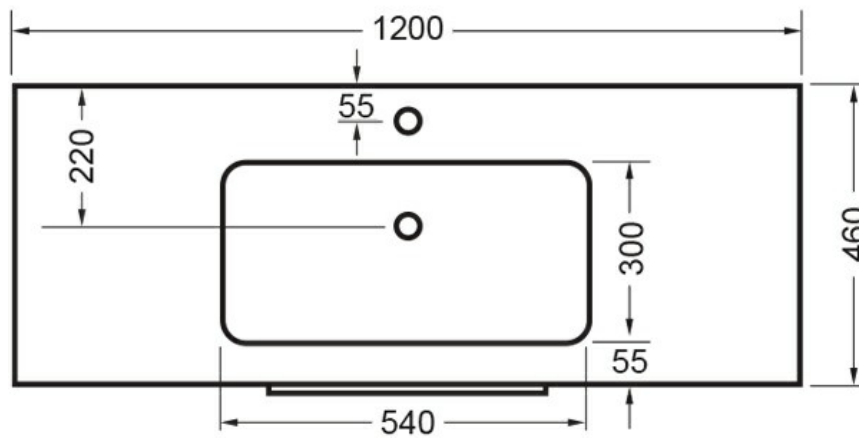
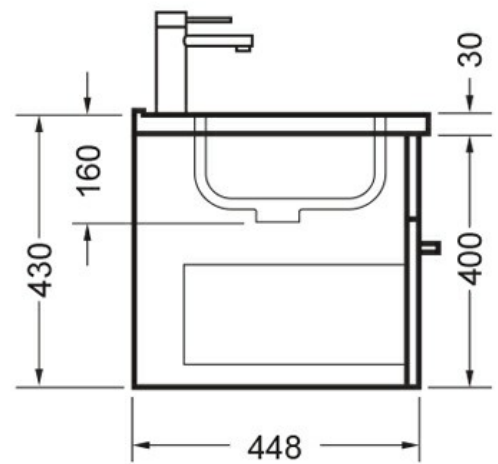
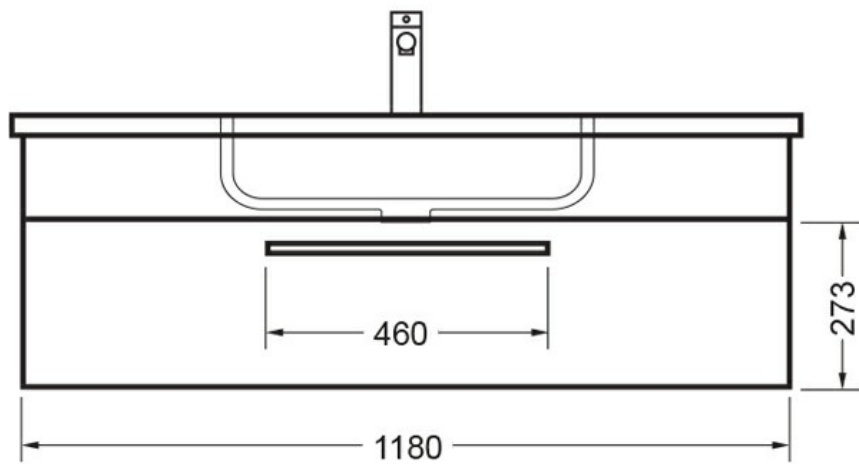

Residential/Light  
Commercial

Suitable for Residential/Light Commercial Use (Kitchens,  
Bathrooms and Laundries in Motels, Hotels and  
Retirement Villages)

5

Guarantee

5 Year Guarantee (Basin &  
Cabinet)

10

Guarantee

10 Year Guarantee (Tavolo Top)



Hafele Lifetime  
Warranty

All Hafele Hardware comes with a Lifetime Warranty.



Delivery

Minimum 15 working days



Hettich Guarantee

All Hettich Hardware comes with a Lifetime Warranty.





Moisture Resistant

Made from Moisture Resistant Board

---



Soft Close Hinges

Incorporates Hettich Soft Close Hinges.

---



Environmental Choice

Product manufactured predominantly from sustainably grown New Zealand plantation pine forests and is Environmental Choice Certified.

---



Made in New Zealand

---

Crisp lines, a clean finish and impressive features are what defines the Verona vanity range.