

Infinity Essences

Vessel Mixer

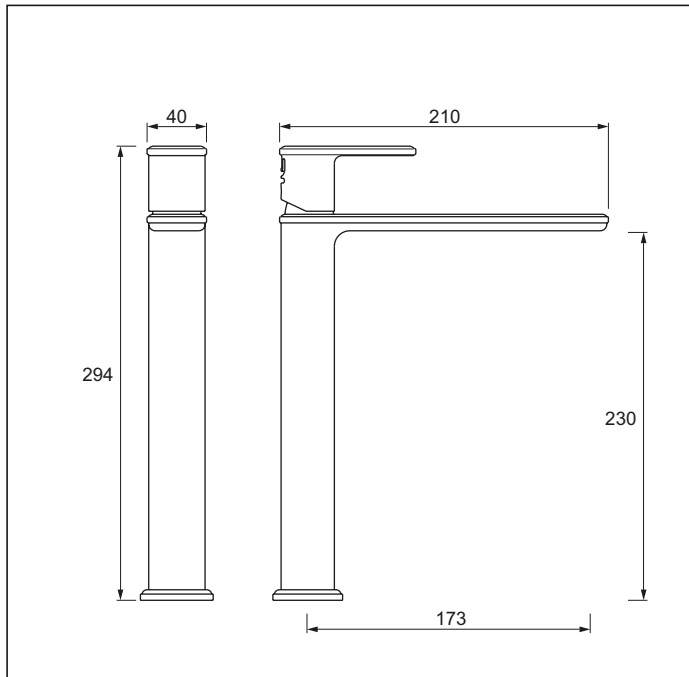

Code: EN VM Chrome Capsule

Code: EN VM WD Wooden Capsule

Finish: Chrome / Wooden Capsule

Spout: Cast, Fixed

Body: Chrome Plated Cast Brass

Water Inlet: Stainless Steel Braided Hoses:
Size: M8 x 1/2" BSP

Water Outlet: M24 Ring with PCA Fitted

Installation: Hole Diameter: Minimum: 28mm
Maximum: 35mm
Bench Thickness: Maximum: 38mm

Mounting Hardware: Stud: 2 x 6mm
Nut: 2 x 9mm A/F
Horseshoe Washer

Cartridge: 25mm Flat Base

Flow: 8 l/min PCA Fitted for Regulated Flow with Mains Pressure System
Max Hot Flow: 3.3 l/min @ 35kPa

Note: Supplied with 1 box of 6 essence fragrance capsules

Suitable for low/unequal & mains pressure systems

Recommended Operational Pressure Range: 35 - 600 kPa
Maximum Operating Temp: 80°C Never to Exceed: 1000 kPa



aquatica



KIWI OWNED COMPANY

NZ • DESIGNED
• ASSEMBLED
• TESTED

Aquatica NZ Limited

9 Saunders Place,
Avondale, Auckland.
Tel: 09-828 2068,
Fax: 09-828 2069
Email: info@aquatica.co.nz
or visit our website:
www.aquatica.co.nz

© copyright Aquatica 2019