

INSTALLATION AND MAINTENANCE INSTRUCTIONS

G SERIES HANDS FREE SOAP DISPENSER



Caroma®

INDEX

- 3** IMPORTANT
- 4** TECHNICAL DATA
- 5** PRE-INSTALLATION INFORMATION
- 6** PACK CONTENTS
- 7-10** INSTALLATION
- 11** FILLING THE SOAP TANK
- 12** SETTINGS ADJUSTEMENT WITH A REMOTE CONTROL
- 13** BATTERIES REPLACEMENT
- 14** SPARE PARTS LIST
- 15** TROUBLE SHOOTING

IMPORTANT

DECK REQUIREMENTS

1. Deck thickness: 50mm maximum
2. Mounting hole (in deck): Ø26-Ø30mm
3. Mounting hole position: <100mm
(centre of dispenser to inside edge of basin/sink)
4. Recommended distance to adjacent tap: 90mm minimum

POWER REQUIREMENTS

Battery operation: IP67 Battery box (6 x D alkaline batteries not included)

Mains operation: 240V 50Hz 3 pin socket

IMPORTANT INFORMATION

1. Viscosity of liquid soap must be within the recommended range (see below).
2. Liquid soaps that are aggressive or abrasive must not be used.
3. Liquid soaps with an extremely low PH value (<6) are not recommended as they may damage the internal components of the dispenser and are damaging to the skin.
4. Discharge volume of liquid soap/cycle may vary depending on its viscosity and temperature.
5. Do not install the system facing a mirror or any other electronic system operated by an infra-red sensor.
6. To prevent reflection problems, it is recommended to keep a minimum distance of 1.50 metres between the soap dispenser and any other objects.

TECHNICAL DATA

1. Soap tank capacity: 1 Litre (35 fl oz)
2. Liquid soap viscosity: 100 to 3800 cPs
3. Standard discharge volume / cycle: 0.8cc (Adjustable)
4. Sensor range: 30-120mm (from sensor window)

TECHNICAL DATA

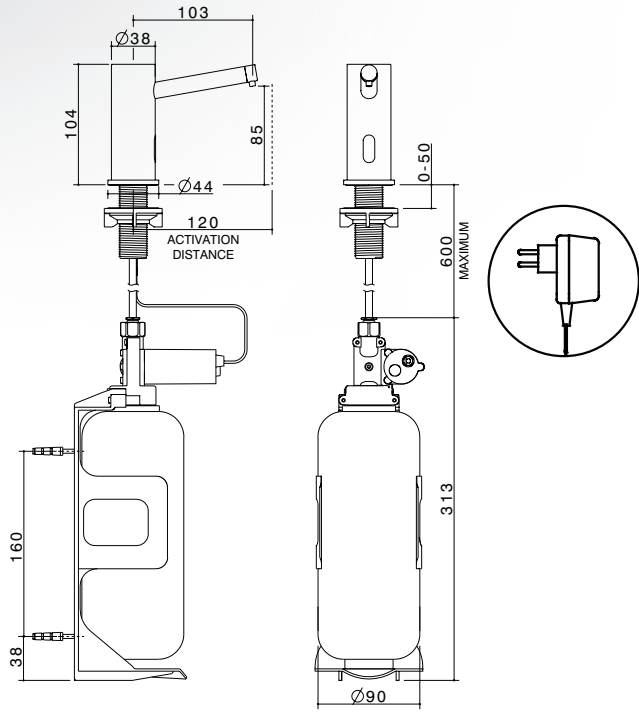

G-Series Hands Free Soap Dispenser G16010E6A

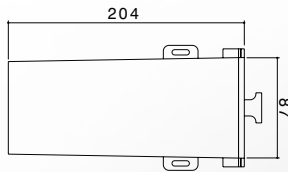

IP67 Battery Box

SP63015

PRE-INSTALLATION INFO

Check contents

Separate all parts from the packaging and check each part with the “Pack contents” section.

Make sure all parts are accounted for before discarding any packaging material.

If any parts are missing, do not attempt to install your touch free soap dispenser until you obtain the missing parts.

Warnings

Do not install the system facing a mirror or any other electronic system operated by an infra-red sensor.

To prevent reflection problems, it is recommended to keep a minimum distance of 1.50 metres between the soap dispenser and any other objects.

Important: Keep in mind that the location of the user hands, while using the mixer or tap nearby should not interfere with the soap dispenser sensor detection area.

PACK CONTENTS

Familiarise yourself with the part names and confirm that the parts are included.

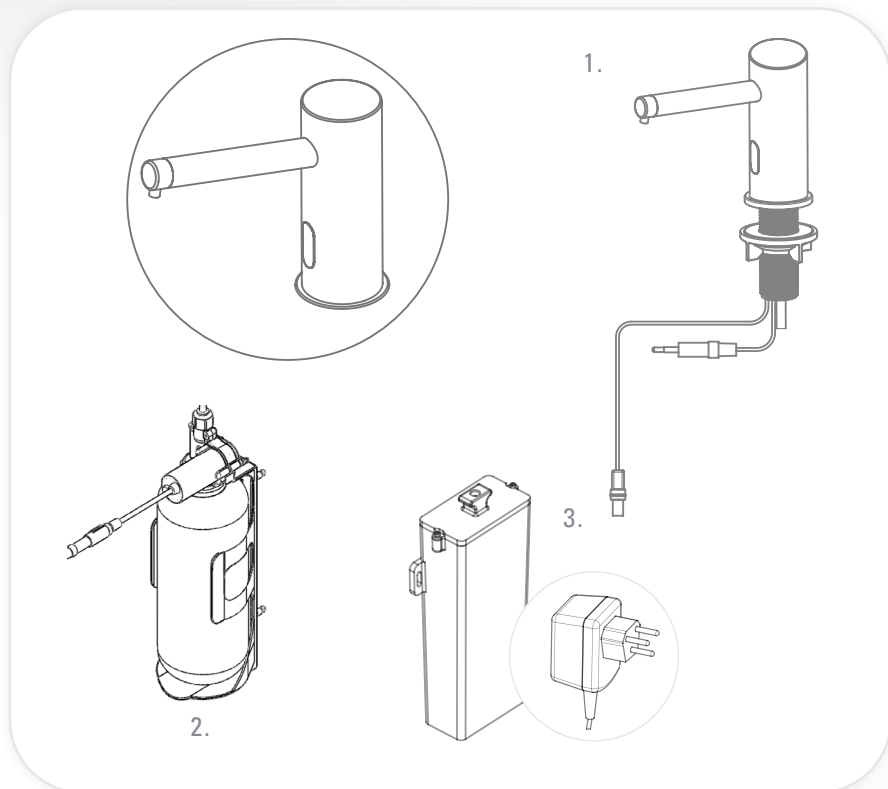

-
1. 1 x Body and fixing accessories
 2. 1 x Soap tank, pump assembly and bottle support
 3. 1 x IP 67 Battery Box for 6xD Alkaline batteries \ Transformer

INSTALLATION

Step 1 – Remove all mounting hardware

Remove the nut and the gasket from the tail of the soap dispenser body.

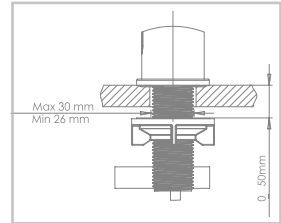

Recommended hole size

Step 2 – Installing the soap dispenser

1. Make sure the 'O' ring is located in the bottom ring of the dispenser.
2. Place the soap dispenser body along with the bottom ring into the hole in the deck.

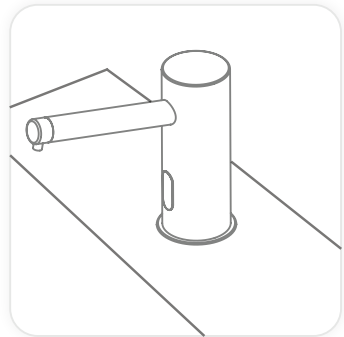

2. Slide the gasket over the tail of the dispenser then screw on the nut and tighten by hand..

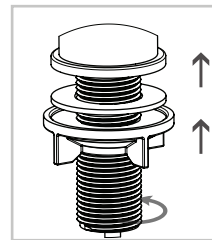

INSTALLATION

3. If you would like to install the soap dispenser without using the supplied bottle support, disassemble the pump from the body support by unscrewing the two adjoining screws and proceed to step 5.

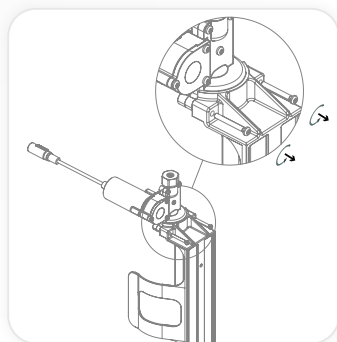

4. Fix the bottle support to the desired location.

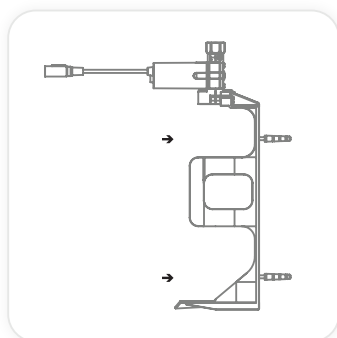

5. Assemble the tube from the pump to the soap dispenser.

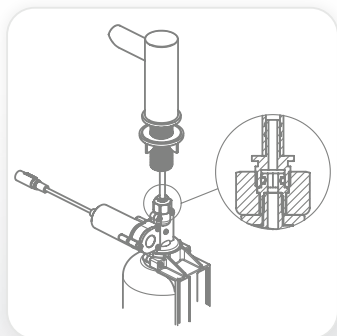

INSTALLATION

6. Screw in the nut at the top of the soap dispenser pump assembly to the soap dispenser body nipple.

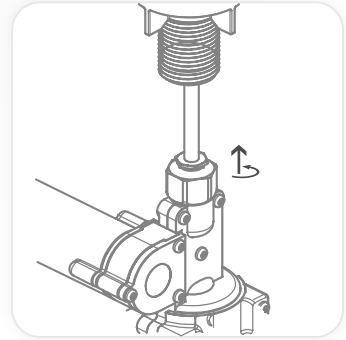

Step 3 - Connecting the power source

1. Remove the protective sticker covering the sensor. Keep away from the sensor range.

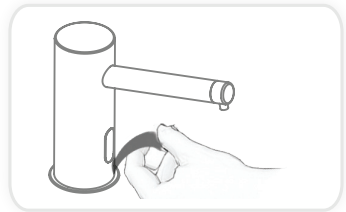

2. a. Connect the motor connector to the power source connector. Please note that since the connector is water proof, some friction might apply.

Important: the 4 contacts connector should be connected properly so that the white o-ring is not visible and a clicking sound is heard.

Pay attention: If the 4 contacts connectors will not be connected properly, the motor will work continuously.

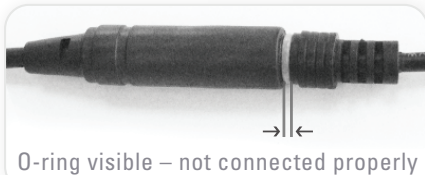

O-ring visible – not connected properly



Connected properly so that only the grooves are visible

INSTALLATION

- b. For battery option: install the battery box at the wall underneath the basin/sink and connect the battery connector
- c. For mains option: plug the transformer into the electricity socket and connect the transformer connector

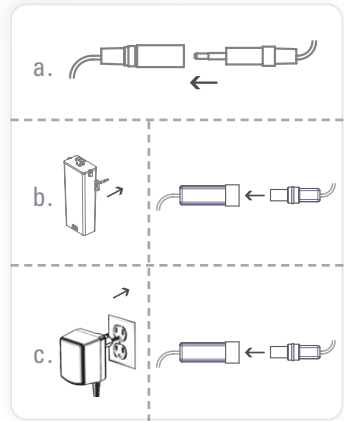

3. Wait about 10 seconds before you put your hands within the sensor range.

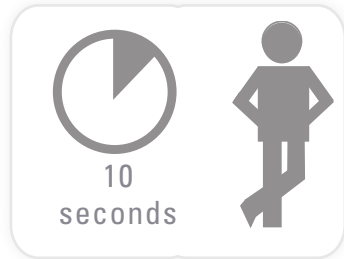

FILLING THE SOAP TANK

1. Unscrew the soap tank from the pump assembly.

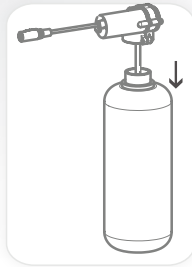

2. Fill in the liquid soap up to the top line.

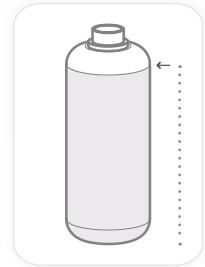

3. **Only if you have a bottle support kit:** insert the bottle with the tube inside the bottle support.

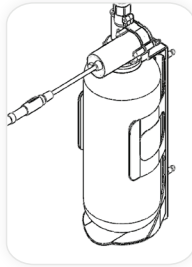

4. Screw the soap tank back to the pump assembly. Make sure the tank is secured firmly in place.



5. Press the refill button located at the back of the pump assembly until soap starts coming out of the soap dispenser spout. This operation can also be done using the soap dispenser remote control Refill function.

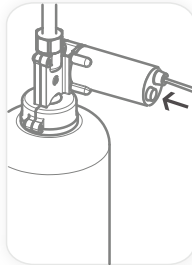

Note: Once the soap in the soap tank has reached the bottom line the soap tank should be refilled. To refill the soap tank please refer to steps 1-5.



SETTINGS ADJUSTEMENT WITH A REMOTE CONTROL

If desired, use the remote control to adjust the soap dispenser settings. Hold the remote control straight in front of the sensor in a distance of about 4-6" (10-15cm).

Attention: Holding the soap dispenser remote control out of the recommended range (too close or too far) may interfere with the remote's activation.

Choose the function you want to adjust by pressing on the function button as following:

① SOAP QUANTITY

The 1-4 drop keys allow the user to choose the desired soap quantity delivered.

① 0.2 to 0.4 ② 0.7 to 0.9 ③ 1.2 to 1.6 ④ 2.1 to 2.3

Indication: continues blink of the red light in the sensor eye.

* The exact soap dosage depends on the soap viscosity and temperature.

② ADJ

This function resets the soap quantity delivered to the factory setting. Press the ADJ button.

Indication: 2 blinks of the red light in the sensor eye.

③ TEMPORARY OFF FUNCTION

This function is ideal to perform any kind of activity in front of the sensor without operating the system (for example, cleaning). The soap dispenser will remain shut for 1 minute when this button is pressed once. To cancel this function and to return to normal operation press the On/Off button again or wait 1 minute.

Indication: OFF – 2 fast blinks, ON – 4 fast blinks

④ REFILL THE SOAP TANK

Once the soap tank has been refilled, press the FILL button. The pump will work for one minute in order for the soap to start coming out of the soap dispenser spout. To stop this activity press the FILL button again.

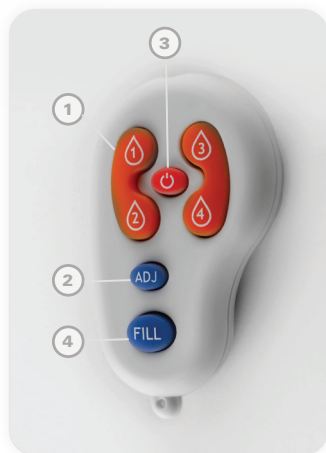

BATTERY REPLACEMENT

Battery option only

When the batteries weaken, the red indicator light will blink at a constant rate when the user's hands are within the sensor range. The batteries must be replaced within two weeks.

To replace the batteries in battery models:

1. Carefully open the battery box, use 2.5 mm Allen key
2. Remove the old batteries
3. Replace the used batteries with new D batteries

NOTE: Do not mix used batteries with new ones.

4. Close the box.

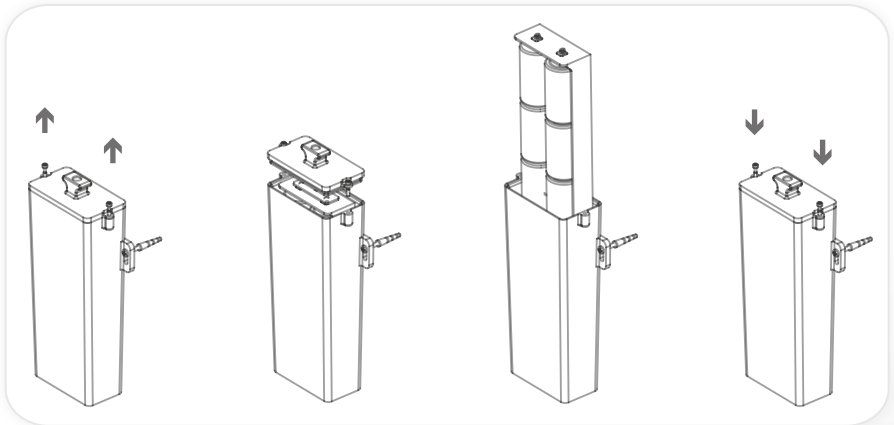

Important: Spent batteries should not be disposed of with normal household waste. Contact your local authority for information on waste disposal and recycling.



MAINTENANCE

SPARE PARTS LIST

CODE

Remote Control	SP63016
IP67 Battery Box	SP63015
G Series Soap Bottle 1 litre	SP63021
G Series Soap Pump 1 litre	SP63022
G Series Soap Bottle Bracket	SP63023

TROUBLE SHOOTING

PROBLEM	INDICATOR	CAUSE	SOLUTION
No soap coming out of the spout	Red light in the sensor flashes continuously when the user's hands are within the sensor's range.	Low battery.	Replace battery. See page 13
	Red light in the sensor flashes (once) and the motor is operating.	Soap has run low or completely out.	Refer to page 11 and refill the soap tank.
		The soap tank has been filled but soap has not reached the spout.	Press the refill button located at the bottom of the pump until soap starts to come out of the spout again.
		The connectors between the motor and the power source are not connected properly.	Connect the connectors properly so that the white o-ring is not visible. Refer to page 9 to see how.
		Sensor is picking up reflections from the washbasin or another object.	Eliminate cause of reflection.
	Red light in the sensor does not flash (once) when user's hands are within the sensor's range.	Connectors between the electronic unit and the pump assembly \ transformer are disconnected or not properly connected.	Connect the electronic unit connectors to the pump assembly and transformer.
Batteries are completely used up.		The batteries must be replaced. See page 13	
Soap coming out from the spout does not stop	Red light flashes (once) and the motor operates.	Soap solidification at the pipe.	Fill the bottle with hot water at 50/60C and run the pump constantly.
		The black connectors between the pump assembly and soap dispenser are not connected properly.	Connect the connectors properly so that the white o-ring is not visible. Refer to page 9 to see how.