

CONTINUOUS FLOW HOT WATER

6-star energy efficiency,
mains pressure delivery,
space and energy
saving options.

Factory-tested,
pre-assembled,
and delivered as
a complete package.

We have two large Rheem Continuous Flow Tankpak systems providing mains pressure water throughout our building. Since building handover, these systems have provided excellent hot water delivery to all our tenants with zero complaints - I'm very happy with the Rheem systems.

Leon Liu, Building Manager -
Vanguard Apartments/Sebel Malvern

CASE STUDY

ICC

SYDNEY, NSW

Challenge

The \$1.5 billion ICC Sydney at Sydney's Darling Harbour is Asia-Pacific's premier integrated convention, exhibition and entertainment precinct. This world-class facility required a reliable hot water solution, capable of hosting three separate events concurrently, including a 8000-capacity red carpet theatre.

Hot Water Solution

Rheem supplied 8 commercial hot water plants, that were used to service the theatre, convention and exhibition centres, including 7 x Rheem Tankpaks, consisting of high-efficiency commercial continuous flow gas water heaters manifolded together with commercial buffer storage. This was combined with a Rheem Raypak gas heater system with commercial buffer storage tanks, along with a commercial solar pre-heat system (used to offset gas consumption).



CONTINUOUS FLOW HOT WATER

FOR CONTINUOUS HOT WATER FLOW
IN HIGH-DEMAND ENVIRONMENTS



NATURAL
GAS & ULPG

6 ★ STAR
ENERGY

FRST
PROTECTION

FAULT
PROTECTION

The continuous flow water heater with 6-star energy efficiency

High energy efficiency

6-star energy rating and 84% thermal efficiency.

Constant temperature.

Compatible with other systems

Compatible with solar, heat pump and waste heat systems. EZ Link[®] two units together for 54L per minute.

Fault protection

Unique Flame Safe[®] technology detects heat exchanger faults and shuts the system down.



External Model

Internal Model

More key features

- Digital temperature display (Tankpak, Multipak, Commpak and Commpak Plus)
- Internal and external models available
- Natural gas and ULPG models
- Frost protection
- Suitable for sanitising applications when set at 82°C

Commercial Continuous Flow Water Heater warranty: 1 year on heat exchanger, 1 year on parts & labour

TECHNICAL DATA

RHEEM COMMERCIAL CONTINUOUS FLOW		EXTERNAL 27L MODEL	INTERNAL 27L MODEL
Model		872627	862627
Delivery Temperature	°C	up to 82	up to 82
Input	MJ/h	205	205
Output	kW	47.5	47.5
Efficiency	%	84	84
Gas Energy Rating	Stars	6	6
Flow Rate @ 25°C Rise	L/min	27	27
Minimum Flow Rate	L/min	2	2
Dimensions			
Height	mm	600	650
Width	mm	350	350
Depth	mm	226	250
Frost Protection		yes	yes
Approximate Weight	kg	23	23
Inlet/Outlet Connections	BSPM	R ³ / ₄ /20	R ³ / ₄ /20
Gas Connection	BSPM	R ³ / ₄ /20	R ³ / ₄ /20
Water Supply Pressure			
Maximum	kPa	1000	1000
Minimum	kPa	140	140
Gas Supply Pressure Range			
Natural Gas	kPa	1.13 – 3.5	1.13 – 3.5
UPLG	kPa	2.75 – 3.5	2.75 – 3.5
Temperature Settings	°C	38, 40, 42, 43, 45, 50, 55, 60, 65, 70, 75, 82	38, 40, 42, 43, 45, 50, 55, 60, 65, 70, 75, 82
Factory Set Temperature	°C	60	60
Co-Axial Flue Specification			
Inner – Material/Diameter	mm	NA	316L or 444/78
Outer – Material/Diameter	mm	NA	Aluminised Steel/127
Maximum Flue Run		NA	13.5m and no bends*
Accessories			
Pipe Cover		320116	NA
Recess Box		320316	NA
Security Bracket		320591	320591
Gas Booster Mounting Kit (suit TP01)		299237**	299237**
EZ Link® Kit Max 60°C (Deluxe Kitchen Controller not included)		299291	299291
Deluxe Temperature Controllers (Max 60°C)			
Kitchen		A299861	A299861
Bathroom 1		A299862	A299862
Bathroom 2		A299863	A299863

* Reduce the maximum length by 1.5m for every 90° bend and by 0.75m for every 45° bend. The flue system is suitable for vertical and horizontal termination when used with the appropriate terminal.

**Kit needs to be ordered separately.

RHEEM TANKPAK

Tankpak 1 (Concept Option)

FOR CONTINUOUS HOT WATER FLOW
IN HIGH DEMAND ENVIRONMENTS



NATURAL
GAS & ULPG

6 ★ STAR
ENERGY

FRST
PROTECTION



The Rheem Tankpak combines the benefits of mains pressure and continuous flow water heating.



Manifolded banks of Continuous Flow Water Heaters (CFWH) meet the requirements of peak demand periods, whilst the storage tank provides buffer for peak simultaneous demands.

How it works

The thermostat senses the water in the storage tank and activates the primary pump, which in turn activates the continuous flow water heaters. Water is drawn from the bottom of the tank and is returned to the hot water outlet at the top of the tank. When the thermostat senses water in the tank at set point, the pump and water heaters are turned off.

Top Down Heating

Rheem Tankpak utilises the top down heating principle. This allows the coldest water to be supplied to the continuous flow water heaters for the longest period of time to maximise the recovery rate whilst providing hot water immediately for use.

Other systems utilise a traditional return fitting on the storage tank, which provides warmer water to the continuous flow water heater. This causes water heaters to modulate the gas input and reduce the effective recovery rate.

TankPak 1 (Concept Option) warranty:
5 years on VE cylinder, 8 years on SS cylinder,
1 year on heat exchanger, 1 year on parts & labour

Range

Rheem Tankpak (concept option) is available from 1 to 10 Continuous Flow Water Heaters (CFWH) with 1, 2 or 3 storage tanks, depending on system size. Larger systems are available on application. Indoor or outdoor CFWH are assembled in banks from 2 to 6 units by the installer, available in natural gas or ULPG. Please note, for systems greater than 6 CFWH the manifolds must be interconnected in equaflo on site by the installer. Ask Rheem how.

Features include:

- 84% thermal efficiency heat source
- Vitreous enamel storage tank up to 82°C operation
- Large flow 50mm storage tank fittings
- High storage tank delivery rating due to innovative top down heating
- Digital temperature display
- Indoor and outdoor models available
- Pre-designed CFWH banks
- All components supplied loose for easy on-site installation

Benefits include:

- Mains pressure performance
- Reduced footprint
- High recovery
- Redundancy backup

TYPICAL INSTALLATION

Typical Installation with TP03 shown

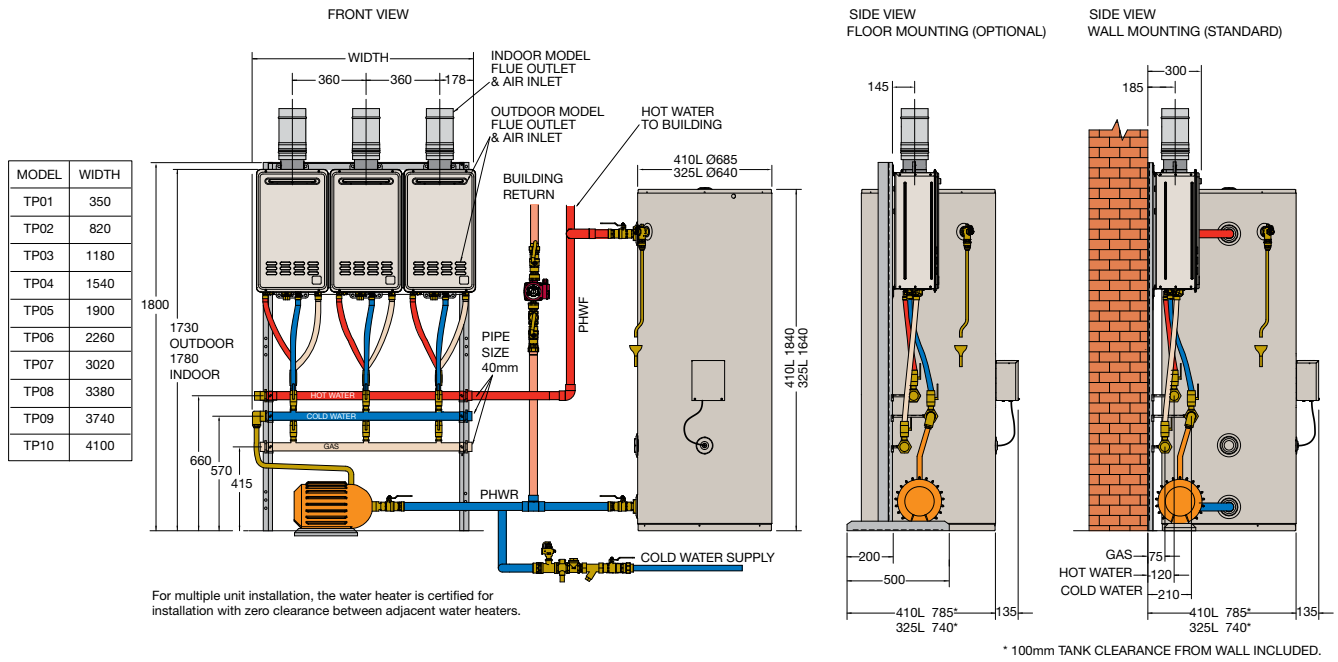

TANKPAK TECHNICAL DATA

Model	No. CFWH	Thermal Input (MJ/h)	Recovery @ 50°C Rise (L/hr)	Storage Tanks	1st Hour Delivery (L)	Primary Flow and Return Pipe Size (mm)*	Gas Pipe Size			Pump Model	Pump Part Number	Weight [^] (kg)
							NG (mm)*	ULPG (mm)				
TPI01 TPE01	1	205	803	A610340	1063	25	20	20	UPS32-80N	56860243	122	
TPI02 TPE02	2	410	1606	A610340	1866	40	40	40	CM 3-2	366084	203	
TPI03 TPE03	3	615	2409	A610340	2669	40	40	40	CM 3-2	366084	228	
TPI04 TPE04	4	820	3213	A610340	3473	40	40	40	CM 3-2	366084	293	
TPI05 TPE05	5	1025	4016	A610430	4344	40	40	40	CM 5-2	366089	340	
TPI06 TPE06	6	1230	4819	A610430	5147	40	40	40	CM 5-2	366089	365	
TPI07 TPE07	7	1435	5622	2x A610340	6142	50	50	40	CM 5-2	366089	510	
TPI08 TPE08	8	1640	6425	2x A610340	6945	50	65	40	CM10-1	366094	580	
TPI09 TPE09	9	1845	7228	2x A610430	7748	50	65	40	CM10-1	366094	647	
TPI10 TPE10	10	2050	8032	2x A610430	8688	50	65	40	CM10-1	366094	672	

* For systems using more than 6 CFWH, each manifold assembly must be plumbed in parallel.

[^] Weight includes CFWH unit, storage tank empty, pump and assumed likely weight of frame and manifolds.

NB: TPI = Internal, TPE = External

TANKPAK SERIES 2®

Prebuilt on a frame

FOR COMMERCIAL
APPLICATIONS OF ALL SIZES



HIGH WIND
RATING

FAST
INSTALLATION

FAST
COMMISSIONING

MEETS
PEAK
DEMAND

Top down heating for
faster hot water delivery
and better redundancy.



High wind certified

Engineer certified for high wind rating (up to 45m depending on the location). Lifting lugs are also engineer certified.

Fast commissioning

TankPak's top down heating design delivers hot water to the building instantly.

Fast installation

Rheem factory-tests each order before supplying the entire CFWH system, including GPOs, pump and controller, so there are no delays on site.

Meets peak demand

TankPak's top-down heating design and tank storage with large flow 50mm fittings, meet peak simultaneous demands.

Built-in redundancy.

Innovative plumbing design provides a direct line from the water heater to the building, which means there's no interruption to hot water supply during maintenance.

Wall Mount (W) / Floor Mount (F) / Back To Back (B)

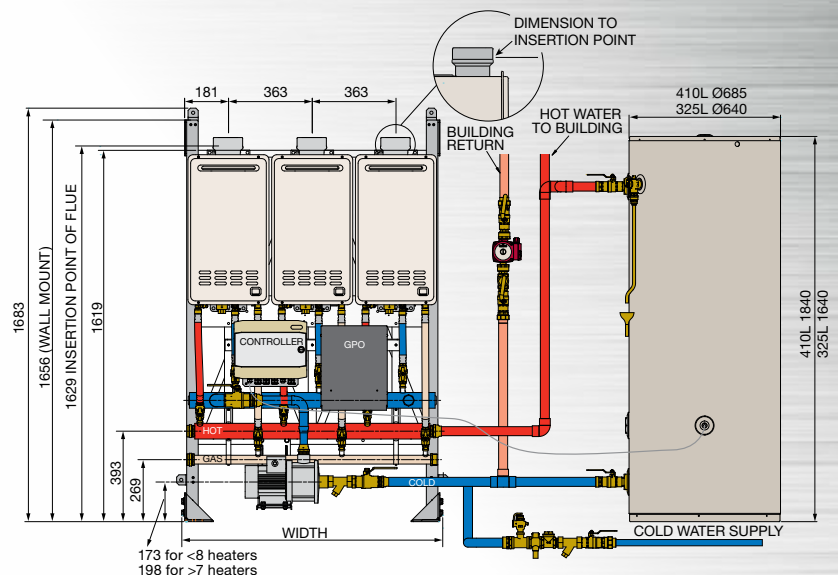

More key features

- Watermark AS-NZS 4020 certified
- Modular frame system allows easy dismantling
- Plumb to right or left-hand side
- Wall and floor-mounted in line and back-to-back options
- Variety of storage tank options suitable for sanitisation applications

TankPak Series 2® warranty: 5 years on VE cylinder, 8 years on SS cylinder, 1 year on heat exchanger, 1 year on parts & labour

TECHNICAL DATA

TANKPAK MODEL	INTERNAL EXTERNAL	S2TPI 02 S2TPE 02	S2TPI 03 S2TPE 03	S2TPI 04 S2TPE 04	S2TPI 05 S2TPE 05	S2TPI 06 S2TPE 06	S2TPI 07 S2TPE 07
Thermal Input	MJ/h	410	615	820	1025	1230	1435
Recovery Rate at 50°C rise	L/hr	1645	2470	3290	4115	4935	5760
Mounting options		W/F	W/F	W/F/B	W/F/B	W/F/B	W/F/B
Storage Tank Options		1 x A610340 1 x A610430	1 x A610340 1 x A610430	1 x A610340 1 x A610430	- 1 x A610430	- 1 x A610430	- 1 x A610430
1st Hour Capacity (340L)	Litres	1970	2795	3615	-	-	-
1st Hour Capacity (430L)	Litres	2055	2880	3700	4525	5345	6170
Electrical Supply (240V/50Hz)	Amps	4.0	4.8	5.5	7.0	7.8	8.6
Electrical Connection		1.8m 10A Plug and Lead					
PHWF & PHWR Pipe Size	mm	25	32	40	40	40	50
Natural Gas Pipe Size	mm	40	40	50	50	50	50
ULPG Pipe Size	mm	32	32	32	32	32	32
Width (Inline)	mm	755	1118	1481	1844	2207	2570
Width (Back to Back)				755	1118	1118	1481
Weight Empty (F/B)*	kg	239	278	314/297	375/338	413/363	458/405

* Weight includes CFWH unit, storage tank empty, pump, frame and preassembled manifolds. Tankpak models with 1 x CFWH are supplied loose with CFWH, pump & controller separately. The CFWH must be mounted on a vertical wall or use Mounting Bracket 299237.

Back To Back (B)

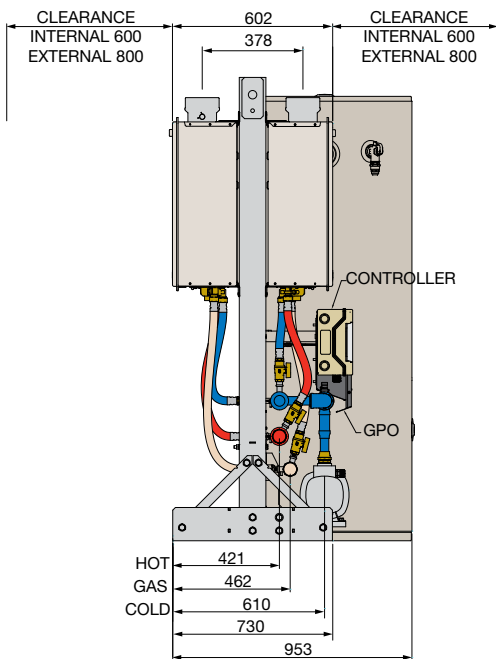

Wall Mount (W)

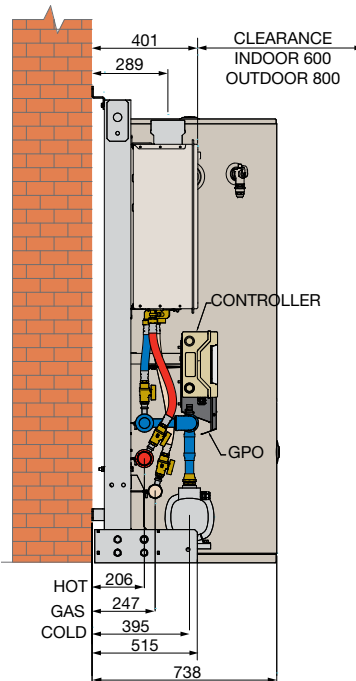

Floor Mount (F)

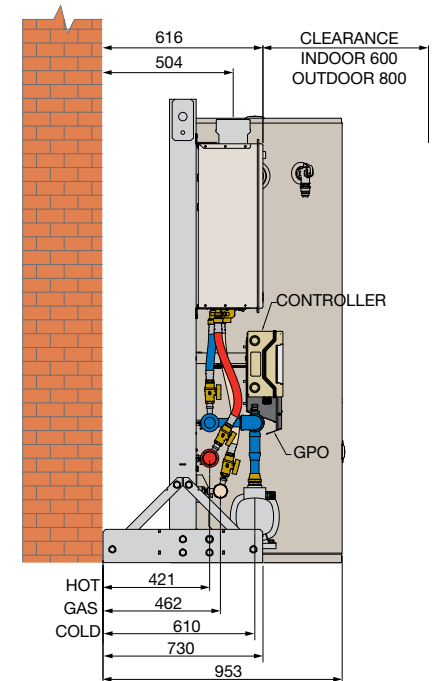

TECHNICAL DATA

TANKPAK MODEL	INTERNAL EXTERNAL	S2TPI 08 S2TPE 08	S2TPI 09 S2TPE 09	S2TPI 10 S2TPE 10	S2TPI 12 S2TPE 12	S2TPI 14 S2TPE 14	S2TPI 16 S2TPE 16	S2TPI 18 S2TPE 18
Thermal Input	MJ/h	1640	1845	2050	2460	2870	3280	3690
Recovery Rate at 50°C rise	L/hr	6580	7405	8225	9875	11520	13165	14810
Mounting options		W/F/B	W/F/B	B	B	B	B	B
Storage Tank Options		-	-	-	-	-	-	-
		2 x A610430	2 x A610430	2 x A610430	2 x A610430	3 x A610430	3 x A610430	3 x A610430
1st Hour Capacity (340L)	Litres	-	-	-	-	-	-	-
1st Hour Capacity (430L)		7400	8225	9045	10695	12750	14395	16040
Electrical Supply (240V/50Hz)	Amps	10.6	11.4	12.2	14.8	15.5	16.9	18.5
Electrical Connection		240V 50Hz Single phase hard wired connection						
PHWF & PHWR Pipe Size	mm	50	50	50	50	65	65	65
Natural Gas Pipe Size	mm	65	65	65	80	80	80	80
UPLG Gas Pipe Size		40	40	40	40	50	50	50
Width (Inline)	mm	2933	3296	-	-	-	-	-
Width (Back to Back)		1481	1844	1844	2207	2570	2933	3296
Weight Empty (F/B)*	kg	617/551	677/622	646	712	897	962	1062

How to specify/order the right model

PRODUCT CODE EXAMPLE	NO. OF UNITS	GAS TYPE	MOUNTING OPTION	NO. OF TANKS AND CAPACITY
S2TPE (external) + or S2TPI (internal)	10 +	N (Natural gas) + or P (UPLG)	B (Back to Back) + or W (Wall Mount) or F (Floor Mount)	D (Deluxe) /2 + 430

Order code result: [S2TPE10NBD/2430](#) For Tankpak Series 2® with 10 Natural Gas units mounted back to back, pre-wired (deluxe) with 2x 430L storage tanks. NB: 340 & 430L tanks can be supplemented or replaced by RT1000-5000L options - see Page 59.

TANKPAK QUICK SIZING GUIDE

Apartments 1 hr peak				Hotel Rooms 1 hr peak	Amenities 30 min peak	Nursing home 2 hr peak	Tankpak Series 2 Model	Recovery @ 50°C Rise (L/hr)	Storage Tank Capacity (L)	First Hour Capacity (L)	Thermal Input (MJ/h)
Studio ^a	1 & 2 bedroom ^a	2 bedroom ^a	2 & 3 bedroom ^a	1-3 Star ^b	No. of showers ^c	No. of beds ^d					
49	21	16	14	24	32	30	S2TP01/1430**	825	410	1235	205
82	35	27	24	41	49	54	S2TP02/1430	1645	410	2055	410
115	50	38	34	57	65	79	S2TP03/1430	2470	410	2880	615
148	64	49	44	74	82	103	S2TP04/1430	3290	410	3700	820
181	78	60	54	90	98	128	S2TP05/1430	4115	410	4525	1025
213	92	71	64	106	115	152	S2TP06/1430	4935	410	5348	1230
246	107	82	74	123	131	176	S2TP07/1430	5760	410	6170	1435
296	128	98	89	148	164	207	S2TP08/2430	6580	820	7400	1640
329	143	109	99	164	180	231	S2TP09/2430	7405	820	8225	1845
361	157	120	109	180	197	255	S2TP10/2430	8225	820	9045	2050
427	186	142	129	213	230	304	S2TP12/2430	9875	820	10695	2460
510	221	170	154	255	279	359	S2TP14/3430	11520	1230	12750	2870
575	250	191	174	287	312	408	S2TP16/3430	13165	1230	14395	3280
641	278	213	194	320	345	457	S2TP18/3430	14810	1230	16040	3690

* Weight includes CFWH unit, storage tank empty, pump, frame and preassembled manifolds. Tankpak models with 1 x CFWH are supplied loose with CFWH, pump & controller separately. The CFWH must be mounted on a vertical wall or use Mounting Bracket 299237.

a Allowance - studio 25L, 1 bedroom 40L, 2 bedroom 75L, 3 bedroom 90L. Calculated on even ratio of apartment mix.

b Allowance - 2 people per room, 25L per person.

c Allowance - 25L per shower.

d Allowance - 37.5L per bed for showering, bed pans, cleaning, 6L per bed for meals, 24L per bed for laundry.

**Concept system only.

FOR CARAVAN PARKS, SMALL STADIUMS AND SPORTS FACILITIES



HIGH EFFICIENCY

FAST INSTALLATION

MEETS PEAK DEMAND

The staged ignition hot water system that meets intermittent high demand.

Meets high demand when needed

Staged ignition system allows large, but intermittent hot water demands, as well as small demands to be met easily, without maintaining heating during unused periods.

Fast and efficient to install

Rheem factory-tests each order before supplying the entire CFWH system, so there are no delays on site.

Tempering

In 60–82°C temperature setting, suitable for use in dead leg and recirculation systems with tempering. In 55°C mode, suitable for use without the need for external tempering devices for dead leg applications only.*

More key features

- Natural gas and ULPG models
- Left or right-hand plumbing
- Wall and floor mount options
- Optional factory-fitted secondary hot water circulator available



* 55°C limited systems are suitable for dead leg applications only. Further tempering may be required. Consult AS3500.4 for details.

MultiPak® warranty: 1 year on heat exchanger, 1 year on parts & labour

TECHNICAL DATA

MULTIPAK MODEL	INTERNAL EXTERNAL	MPI 02 MPE 02	MPI 03 MPE 03	MPI 04 MPE 04	MPI 05 MPE 05	MPI 06 MPE 06
Input	MJ/h	410	615	820	1,025	1,230
Recovery Rate at 50°C rise	L/hr	1,645	2,470	3,290	4,115	4,935
Maximum Flow Rate at 50°C rise	L/min	27	41	54	68	81
Minimum Flow Rate	L/min	2.0	2.0	2.0	2.0	2.0
Approx Weight	kg	95	120	185	210	235
Wall Mount		standard	standard	standard	standard	standard
Free Standing Frame (FSF)		optional	optional	optional	optional	optional
Electrical Supply (240V/50Hz)	Amps	1.50	2.25	3.0	3.75	4.5
Electrical Connection	1.8m 10A Plug and Lead per CFWH					
Dimensions						
Width	mm	820	1180	1540	1900	2260
Depth (Wall Mount / Free Standing Frame)	mm	360/500	360/500	360/500	360/500	360/500
Frost Protection		Yes	Yes	Yes	Yes	Yes
Accessories - Secondary circulator*	part number	299658	299658	299658	299658	299658

*Secondary hot water circulator option not available on systems set to deliver 55°C

Front view

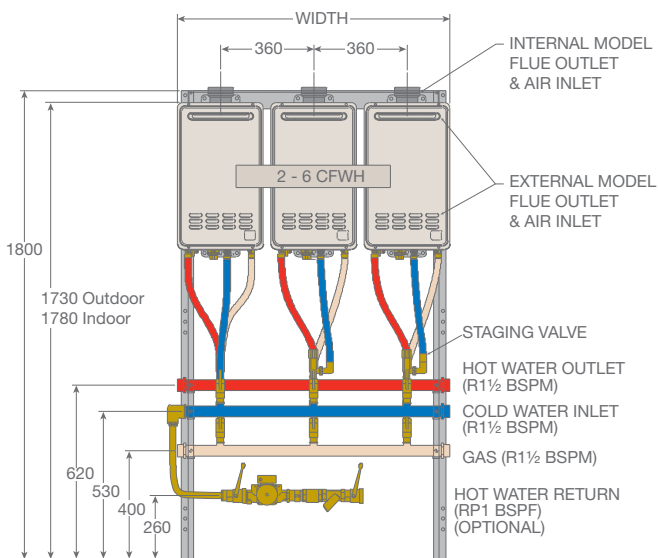

**These dimensions are applicable only for 2 and 3 Multipak systems

Side view floor mounting

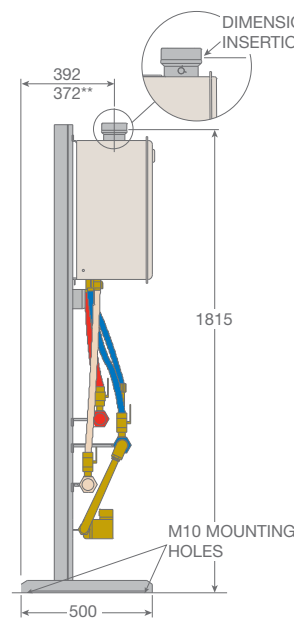

Side view wall mounting

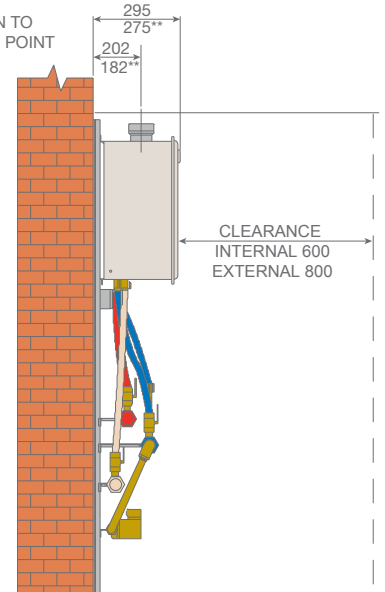

FOR SMALL TO MEDIUM
COMMERCIAL APPLICATIONS



NATURAL
GAS ONLY



SMALL

FAST
INSTALLATION

MAINS
PRESSURE



Tankless mains pressure performance.

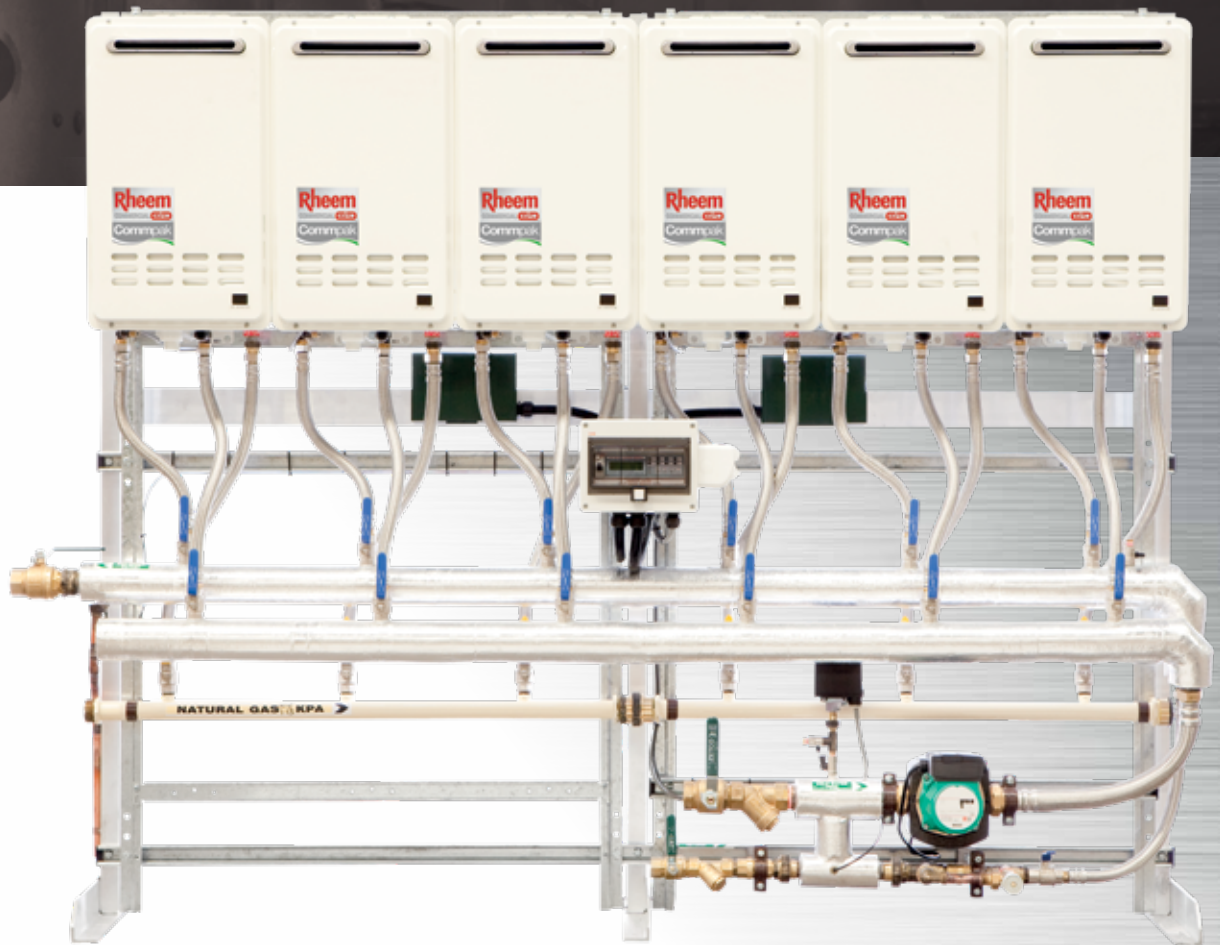

Mains pressure hot water in a small footprint

Sophisticated electronics and pump technology equalises hot and cold water pressures, and a differential set point combined with the thermal mass in the system piping replicates storage.

Fast and efficient to install

Rheem factory-tests each order before supplying the entire CFWH system, including GPOs, pump and controller, so there are no delays on site.

BMS capable

Central control operation with fault monitoring.

More key features

- Optional Duty/Standby pumps for additional redundancy
- Install inline up to 6 on one frame
- Loss of prime protection – turns off Commpak® system if water pressure is lost

CommPak® warranty: 1 year on heat exchanger, 1 year on parts & labour

TECHNICAL DATA

COMMPAK MODEL	INTERNAL EXTERNAL	CPI 02 CPE 02	CPI 03 CPE 03	CPI 04 CPE 04	CPI 05 CPE 05	CPI 06 CPE 06
Input	MJ/h	410	615	820	1,025	1,230
Recovery Rate at 50°C rise	L/hr	1,645	2,470	3,290	4,115	4,935
Peak Flow Rate at 50°C rise	L/min	27	41	54	68	81
Approx Weight	kg	120	150	220	245	270
Free Standing Frame (FSF)		standard	standard	standard	standard	standard
Electrical Supply (240V/50Hz)	Amps*	3.62	4.62	5.62	6.62	7.92
Electrical Connection		Hard Wired	Hard Wired	Hard Wired	Hard Wired	Hard Wired
Dimensions						
Width	mm	1330	1330	1690	2050	2410
Depth (Free Standing Frame)	mm	500	500	500	500	500
Frost Protection		Yes	Yes	Yes	Yes	Yes
Accessories - Duty/Standby pump	part number	299659	299659	299659	299659	299659

* Single pump. Add 1.62 Amps for Duty/Standby pump option.

Front View

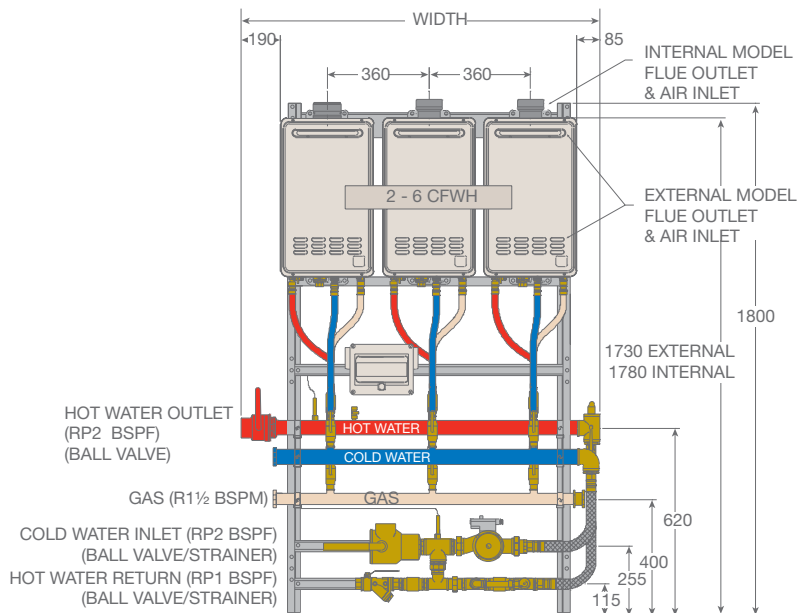

Side view floor mounting

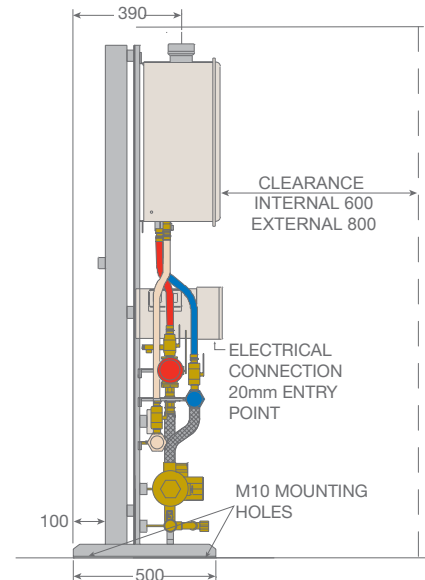

FOR LARGE COMMERCIAL APPLICATIONS



NATURAL GAS ONLY

BUILT-IN REDUNDANCY

SMALL

FAST INSTALLATION

MAINS PRESSURE



Staged tankless mains pressure and built-in redundancy, in a small footprint.

Built-in redundancy and extended life

Commpak Plus® stages half of the pak with one pump, depending on demand, extending water heater and pump life.

Mains pressure hot water in a small footprint.

Sophisticated electronics and pump technology equalises hot and cold water pressures. A differential set point combined with the thermal mass in the system piping replicates storage.

Fast and efficient to install

Rheem factory-tests each order before supplying the entire CFWH system, including GPOs, pump and controller, so there are no delays on site.

BMS capable

Central control operation with fault monitoring.

More key features:

- Loss of prime protection – turns off Commpak Plus® system if water pressure is lost.
- In-line or back to back arrangements are available to meet plant room space availability (model dependent).



Photo: Back to back 18 Unit Commpak Plus®

Inline 7 -12 Commpak Plus®

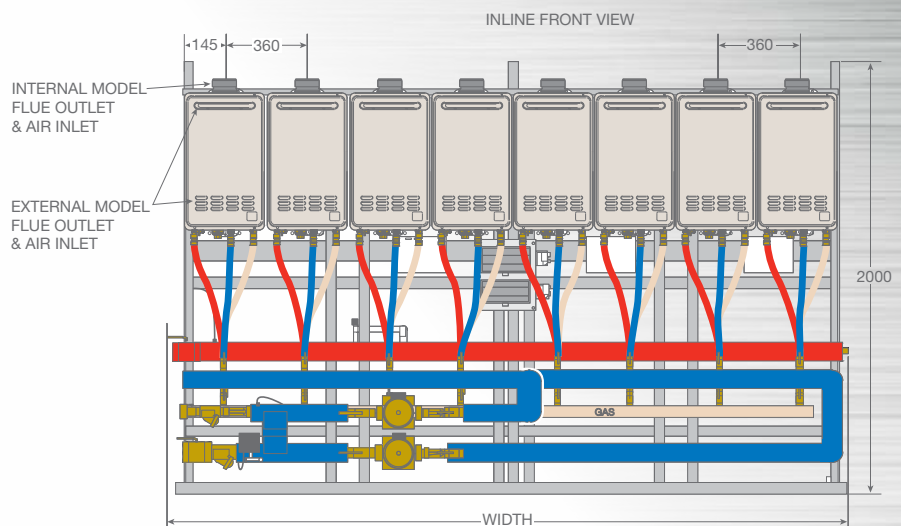

Commpak Plus® warranty: 1 year on heat exchanger, 1 year parts & labour

TECHNICAL DATA

COMMPAK PLUS MODEL	INTERNAL EXTERNAL	CPI 07 CPE 07	CPI 08 CPE 08	CPI 09 CPE 09	CPI 10 CPE 10	CPI 11 CPE 11	CPI 12 CPE 12	CPI 14 CPE 14	CPI 16 CPE 16	CPI 18 CPE 18
Input	MJ/h	1435	1640	1845	2050	2255	2460	2870	3280	3690
Recovery Rate at 50°C rise	L/hr	5761	6584	7407	8230	9053	9876	11522	13168	14814
Maximum Flow Rate at 50°C rise	L/min	96.0	109.6	123.3	137.0	150.7	164.4	191.8	219.2	246.6
Approx Weight	kg	350	380	410	440	470	500	570	640	710
Cold Water/Hot Water										
7-14: Threaded Connection	BSPF	RP2	RP2	RP2	RP2	RP2	RP2	RP2	-	-
16-36: Table E Flanged End	mm	-	-	-	-	-	-	-	65	65
Return	BSPF	RP1	RP1	RP1	RP1	RP1	RP1	RP1¼	RP1¼	RP1¼
Gas	BSPM	R2	R2	R2	R2	R2	R2	R2	R2	R2½
Electrical Supply (240V/50Hz)	Amps	10.24	11.24	12.24	13.24	14.24	15.24	17.24	-	-
Electrical Supply (415V/3 phase/50Hz)	Amps	-	-	-	-	-	-	-	11.0	11.0
Dimensions										
Width - inline	mm	2670	3030	3390	3750	4110	4470	-	-	-
Width - back to back	mm	1980	1980	2340	2340	2700	2700	3310	3670	4030
Frost Protection		Yes	Yes	Yes	Yes	Yes	Yes	Yes	Yes	Yes
Relief Valve Setting	kPa	1000	1000	1000	1000	1000	1000	1000	1000	1000
Water Supply Pressure										
Minimum/Maximum	kPa	140/800	140/800	140/800	140/800	140/800	140/800	140/800	140/800	140/800

Inline 7 -12 Commpak Plus® Side view

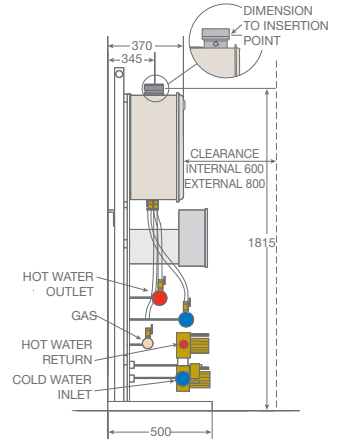

COMMPAK PLUS MODEL	INTERNAL EXTERNAL	CPI 20 CPE 20	CPI 22 CPE 22	CPI 24 CPE 24	CPI 26 CPE 26	CPI 28 CPE 28	CPI 30 CPE 30	CPI 32 CPE 32	CPI 34 CPE 34	CPI 36 CPE 36
Input	MJ/h	4100	4510	4920	5330	5740	6150	6560	6970	7380
Recovery Rate at 50°C rise	L/hr	16460	18106	19752	21398	23044	24690	26336	27982	29628
Maximum Flow Rate at 50°C rise	L/min	274.0	301.4	328.8	356.2	383.6	411.0	438.4	465.8	493.2
Approx Weight	kg	780	850	920	990	1060	1130	1200	1270	1340
Cold Water/Hot Water										
7-12: Threaded Connection	BSPF	-	-	-	-	-	-	-	-	-
14-36: Table E Flanged End	mm	65	80	80	80	80	100	100	100	100
Return	BSPF	RP2¼	RP1½	RP1½	RP1½	RP1½	RP2	RP2	RP2	RP2
Gas	BSPM	R2½	R2½	R2½	R2½	R2½	R2½	R2½	R3	R3
Electrical Supply (240V/50Hz)	Amps	-	-	-	-	-	-	-	-	-
Electrical Supply (415V/3 phase/50Hz)	Amps	13.0	14.0	14.0	14.0	15.0	17.0	17.0	17.0	17.0
Dimensions										
Width - inline	mm	-	-	-	-	-	-	-	-	-
Width - back to back	mm	4390	4750	5110	5470	5830	6190	6550	6910	7270
Frost Protection		Yes	Yes	Yes	Yes	Yes	Yes	Yes	Yes	Yes
Relief Valve Setting	kPa	1000	1000	1000	1000	1000	1000	1000	1000	1000
Water Supply Pressure										
Minimum/Maximum	kPa	140/800	140/800	140/800	140/800	140/800	140/800	140/800	140/800	140/800

Back to back 7 - 36 Commpak Plus® Side view

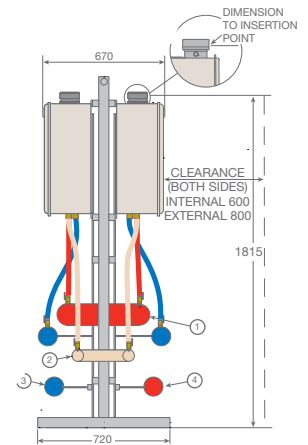

Back to back 7 - 36 Commpak Plus®

Plan view

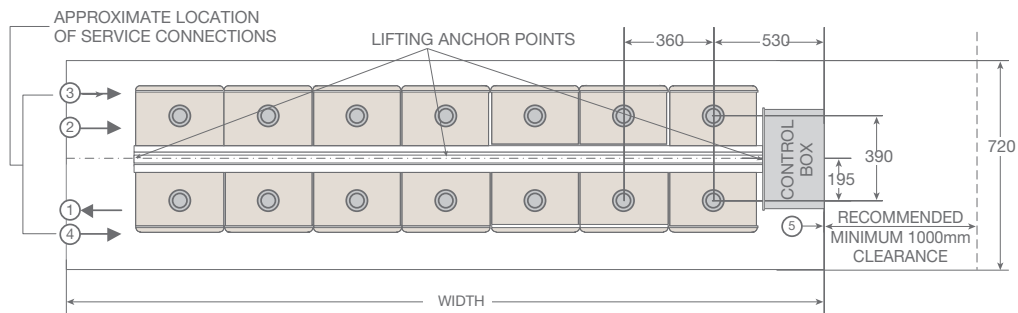

- ① HOT WATER OUTLET
- ② GAS
- ③ COLD WATER INLET
- ④ HOT WATER RETURN
- ⑤ PRESSURE RELIEF VALVE OUTLET

INDOOR INSTALLATION TIPS

Here's a guide to selecting the flue components you need:

- The overall dimension of each flue piece is shown in the drawings.
- Allow approximately 35mm for insertion of each flue piece.
- Determine the lineal distance and number of 45° and/or 90° bends between the top of the water heater and flue terminal. Note: the bottom edge of a vertical flue terminal must be 500mm away from the nearest structure in accordance with AS/NZS 5601.1.
- Flashing is required to be installed where a vertical flue section penetrates the roof line (not supplied).
- Where required, a condensate trap must be installed and filled with water to prevent spillage of products of combustion, and the hose drained to the sewer or outside.
- Separate ventilation for combustion is not required, as the air for combustion is supplied in the flue outer.
- The flue system is certified to be installed with zero clearances between the water heaters and combustible materials.
- Flue termination must comply with the requirements of AS/NZS 5601.1.
- Flue penetrations through walls and ceilings must be sealed in accordance with local fire regulations.
- The maximum flue length with no bends is 13.5m. Reduce the maximum length by 1.5m for every 90° bend and by 0.75m for every 45° bend.
- The flue system is suitable for vertical and horizontal termination when used with the appropriate terminal.

Horizontal terminal adjacent wall

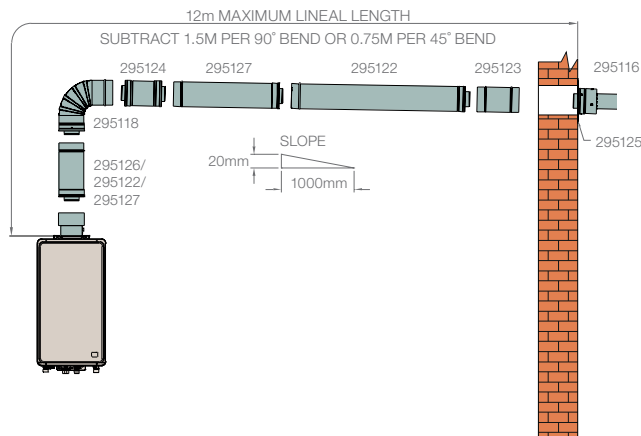

Vertical Terminal

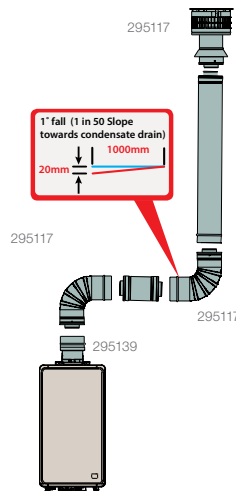

Direct vent horizontal wall

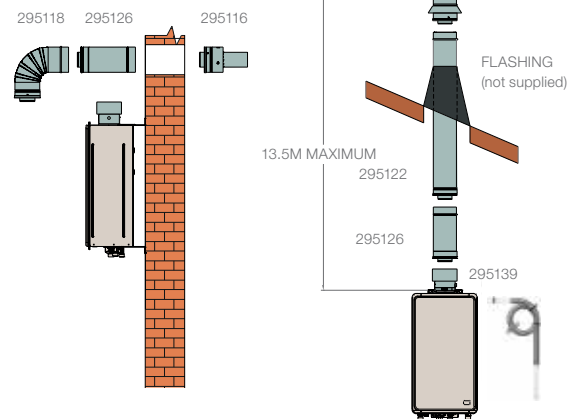

Continuous Flow Flue Kits

Use the following table as a guide for selecting a Rheem 27 Indoor Continuous Flow flue kit. Please note these are base kits only. Further components may be necessary for some installations.

PART NO.	DESCRIPTION	KIT INCLUDES	KIT LENGTH
318280	Vertical Flue Kit	1 x Vertical Terminal (295117)	1200mm
		1 x Straight Length 900mm (295122)	
		1 x Trim Ring (295125)	
		1 x Condensate Trap (295139)	
318278	Horizontal Flue Kit Side Exit	1 x Horizontal Terminal (295116)	1320mm
		2 x Trim Ring (295125)	
		1 x Straight Length 900mm (295122)	
		1 x 90° Bend (295118)	
318279	Horizontal Flue Kit Rear Exit	1 x Horizontal Terminal (295116)	720mm
		2 x Trim Ring (295125)	
		1 x Straight Length 300mm (295126)	
		1 x 90° Bend (295118)	



Rheem INTERNAL CFWH must only be installed using certified Rheem coaxial flue components.

Do not use any other type of flue system. Carefully follow the installation instructions.

FLUE COMPONENTS

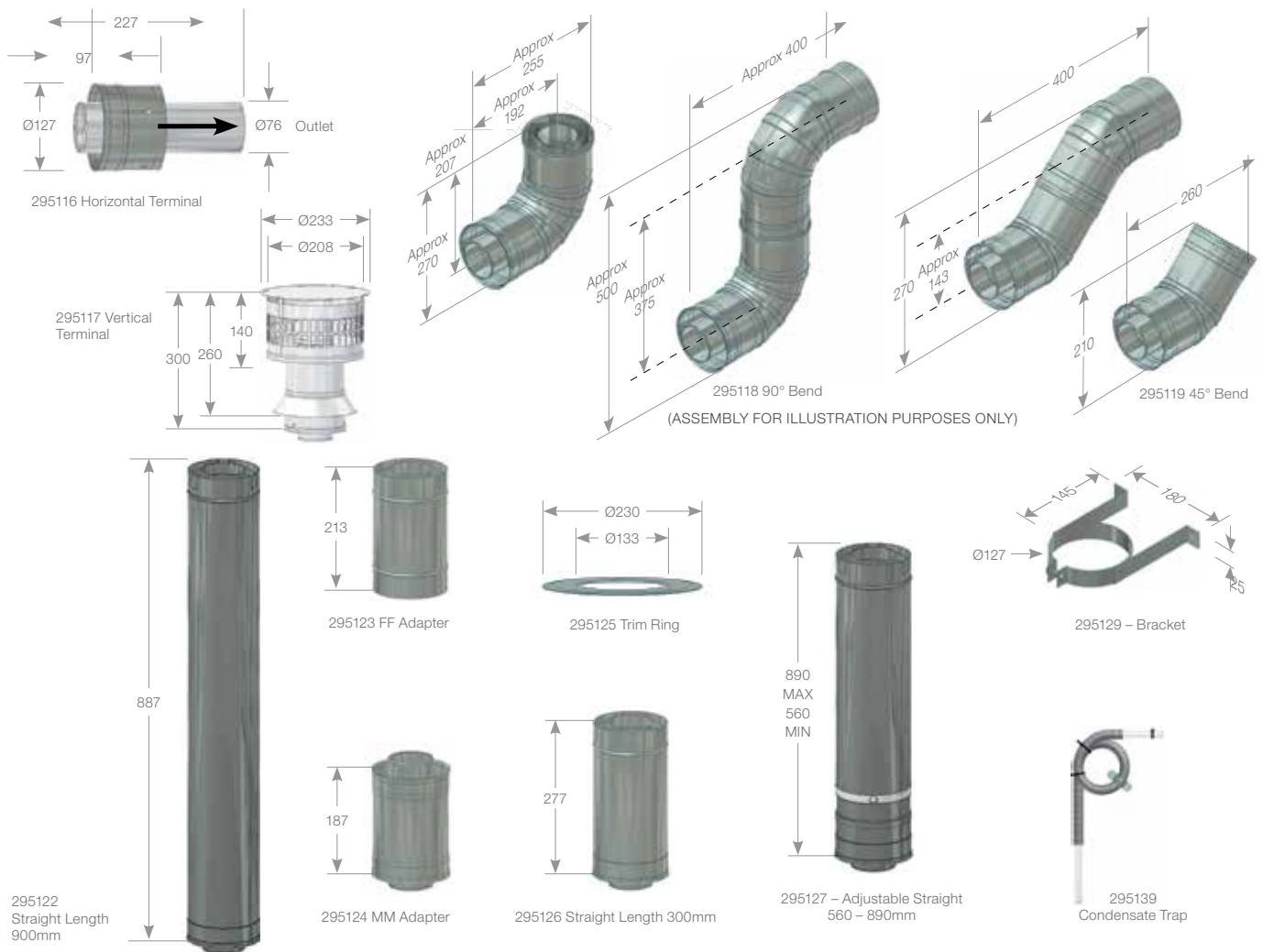

Use the following table as a guide to selecting Rheem Continuous Flow flue components:

P/NO	DESCRIPTION	WHERE USED
295116	Horizontal Terminal	Required where flue terminates horizontally or vertically
295117	Vertical Terminal	Required where flue terminates vertically
295118	90° Bend	Maximum of 5 per installation
295119	45° Bend	Maximum of 10 per installation (with no 90° bends)
295122	Straight Length 900mm	Long straight sections
295123	Female Female Adapter	Required to reverse flue pipe direction to allow condensate to drain away correctly from water heater in long horizontal sections of horizontally terminating flues
295124	Male Male Adapter	Required to reverse flue pipe direction to allow condensate to drain away correctly from water heater in long horizontal sections of horizontally terminating flues
295125	Trim Ring (optional)	Conceal internal and/or external hole in wall for horizontally terminating flues
295126	Straight Length 300mm	Short straight sections
295127	Adjustable Length 560 – 890mm	Allows to trim flue to exact length required
295129	Bracket	Support flue at intervals not exceeding 2m and after any bend
295139	Condensate Trap	Required with every condensate drain. Can be connected to a common waste

CO-AXIAL FLUE SPECIFICATION	MATERIAL/DIAMETER
Inner flue	316 or 444SS/75
Outer flue	Aluminised Steel/125