

Infinity Elegance

Basin Mixer

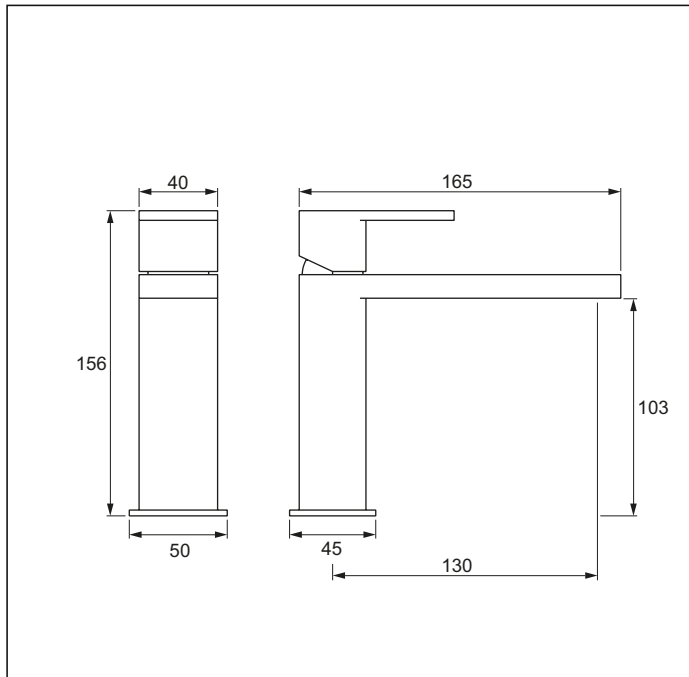

Code: EG BASM BLK

Finish: Matte black with carbon fibre detailing on spout

Spout: Fixed

Water Inlet: Stainless Steel Inlet Hoses:

Size: M8 x 1/2" BSP

Water Outlet: M24 ring with PCA fitted

Dress Ring supplied with O-ring seal

Installation Hole Diameter: Minimum: 32mm

Maximum: 41mm

Mounting Hardware: Stud: 2 x 6mm

Nut: 2 x 9mm A/F

Horseshoe Washer

Cartridge: 25k Flat base

Flow: 5.7 l/min PCA fitted for regulated flow with mains pressure system

Max hot @ 35 kPa = 3.4 l/min

Suitable for mains pressure only

Recommended Operational Pressure Range: 150 - 600 kPa

Maximum Operating Temp: 80°C Never to Exceed: 1000 kPa

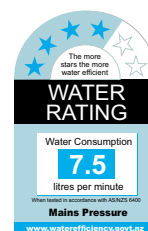

aquatica



KIWI OWNED COMPANY

NZ • DESIGNED
• ASSEMBLED
• TESTED

Aquatica NZ Limited

9 Saunders Place,
Avondale, Auckland.

Tel: 09-828 2068,

Fax: 09-828 2069

Email: info@aquatica.co.nz

or visit our website:

www.aquatica.co.nz

© copyright Aquatica 2019