

# Infinity Elements

## Basin Mixer

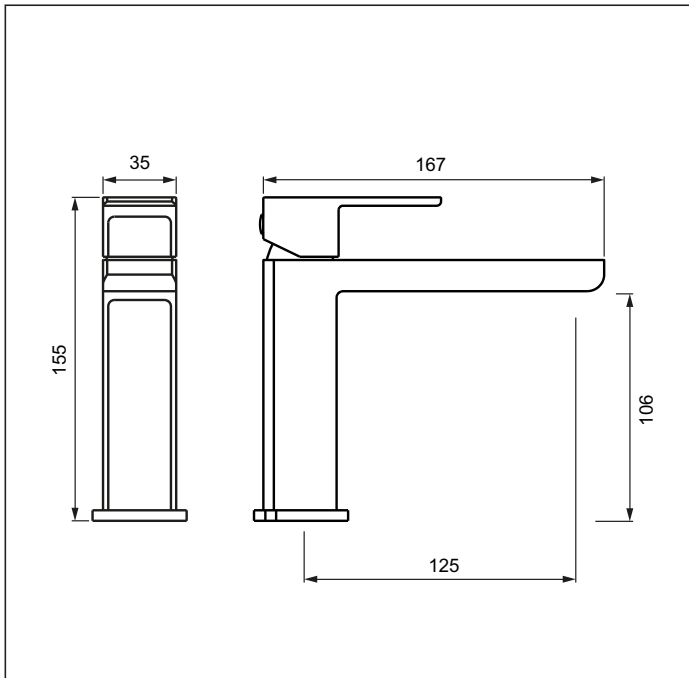

**Code: EM BASM WM** White Marble Insert

**Code: EM BASM BM** Black Marble Insert

**Finish:** Chrome

**Spout:** Fixed

**Water Inlet:** 1/2" BSP Female

**Water Outlet:** M24 Slim Air PCA Fitted

**Installation:** Hole Diameter: Minimum: 28mm

Maximum: 34mm

Bench Thickness: Maximum: 28mm

**Mounting:** Mounting Hardware: Stud: 2 x 6mm

Nut: 2 x 9mm A/F

Horseshoe Washer

Dress ring supplied with base seal

**Flow:** 5.7 l/min PCA Fitted for Regulated Flow with Mains Pressure System

**Max water flow:** @ 35kPa = 2.5 l/min

### Suitable for mains pressure only

Recommended Operational Pressure Range: 150 - 600 kPa

Maximum Operating Temp: 80°C Never to Exceed: 1000 kPa



# aquatica



KIWI OWNED COMPANY

**NZ** • DESIGNED  
• ASSEMBLED  
• TESTED

**Aquatica NZ Limited**

9 Saunders Place,  
Avondale, Auckland.

Tel: 09-828 2068,

Fax: 09-828 2069

Email: [info@aquatica.co.nz](mailto:info@aquatica.co.nz)

or visit our website:

[www.aquatica.co.nz](http://www.aquatica.co.nz)

© copyright Aquatica 2019