

## Extractable Kitchen Mixer



FWK396BN

Doppia Extractable Kitchen Mixer Brushed Nickel

Doppia extractable kitchen mixer in a brushed nickel finish.  
 388mm overall height x 226mm reach  
 Recommended working pressure 200 - 500kPa (balanced)  
 Ceramic disc cartridge  
 35mm hole cut out size required for installation

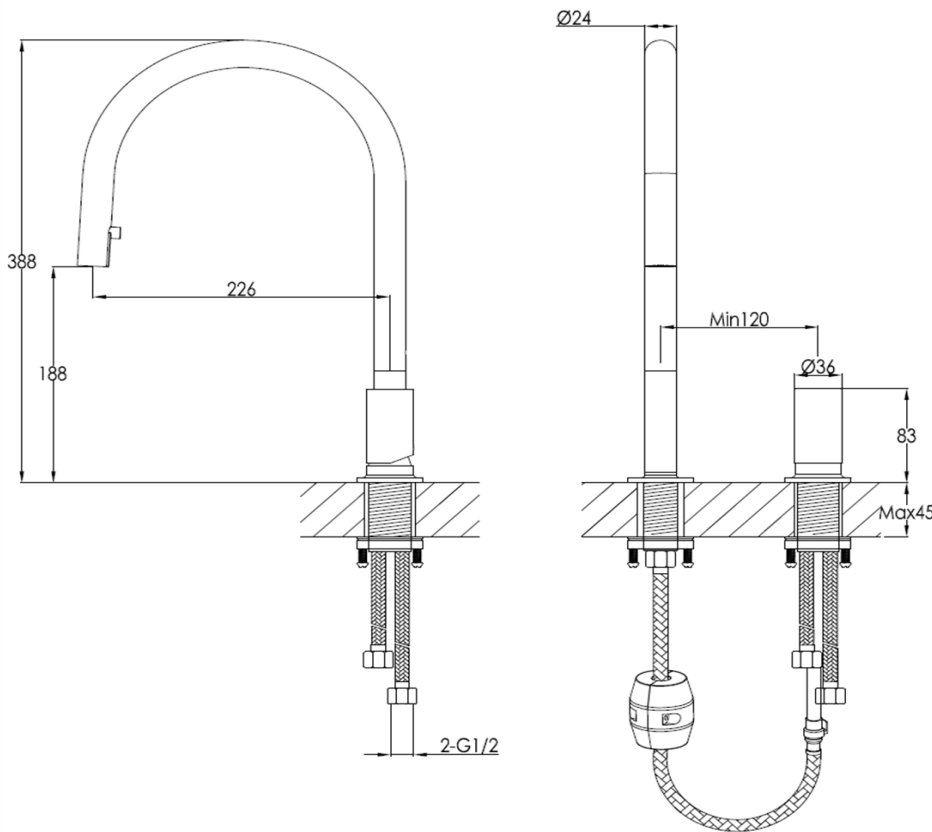

### CARE AND USE

#### Tapware

All finishes are smooth, abrasion resistant, corrosion resistant, fade-proof and easy to clean. All finishes are super hard wearing surfaces that won't chip, peel or tarnish with normal use. All surfaces should be regularly wiped clean with non scouring, neutral wash solutions.

### LIMITED PRODUCT WARRANTIES

To be read in conjunction with and subject to all terms and conditions contained in the Waterware 'Producer Statement' available on-line (<http://www.waterware.co.nz/media-downloads>) From date of purchase, Waterware Services warrants products from the following categories to be free from manufacturing defect subject to exclusions (if applicable):

Category	Domestic Installations	Commercial Installations	Exclusions	Wels
Tapware   10 year conditional warranty	5 years parts and labour, 6-10 years parts only	1 year parts and labour	Handshowers and Hoses	5 Star 4.5L/min