

DESCRIPTION	
CODE	FINISH
HWCT40	PLASTIC

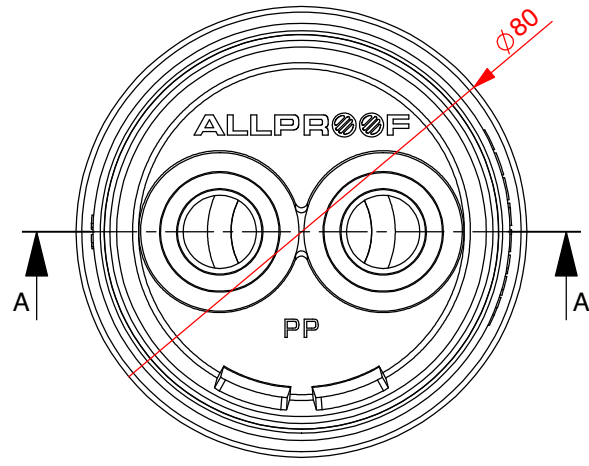

TOP

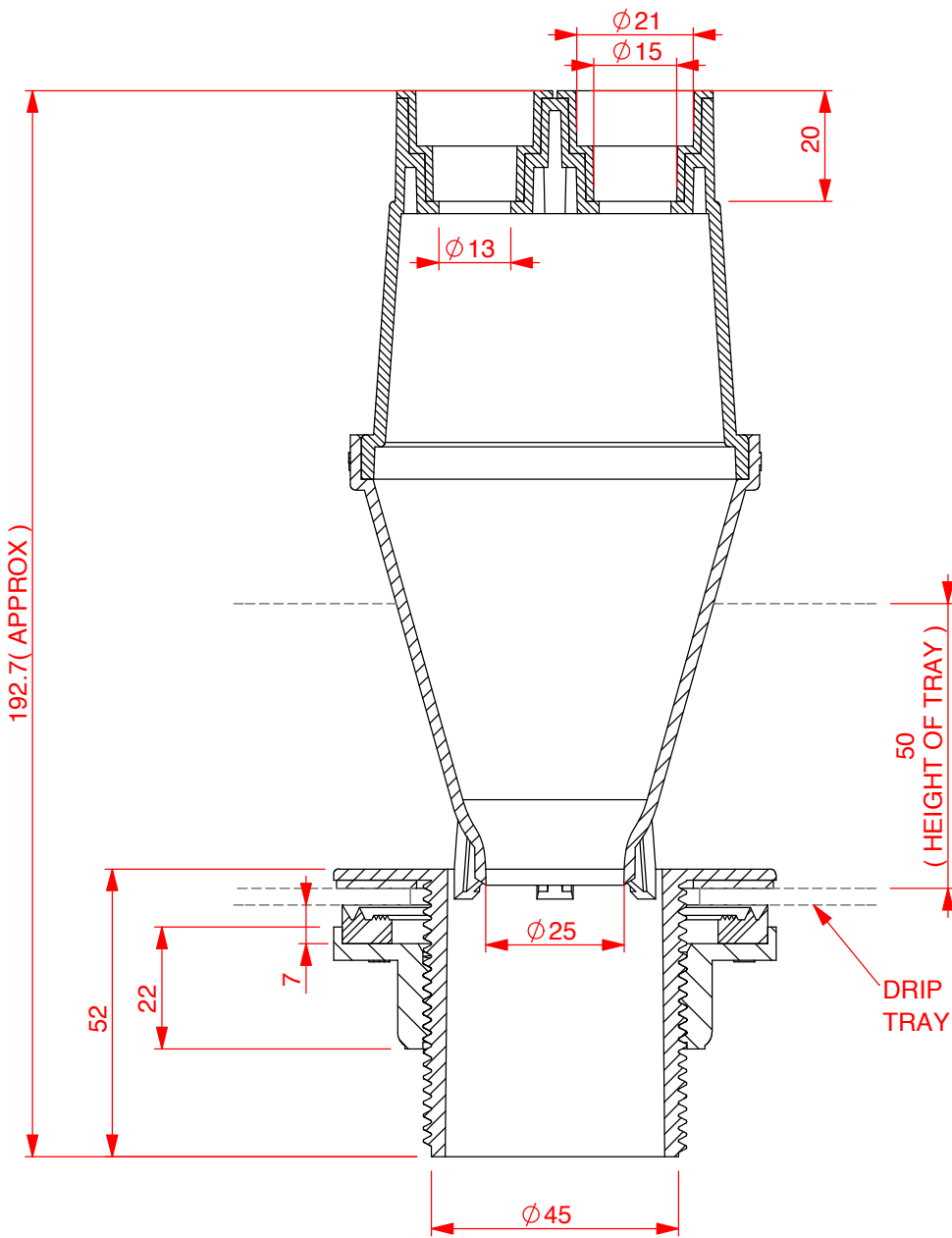

SECTION A-A

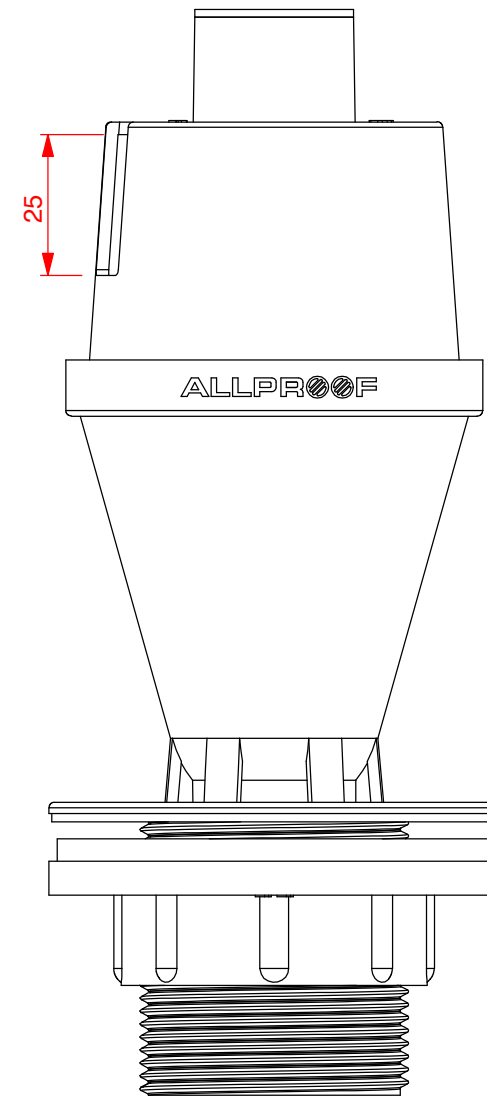

SIDE

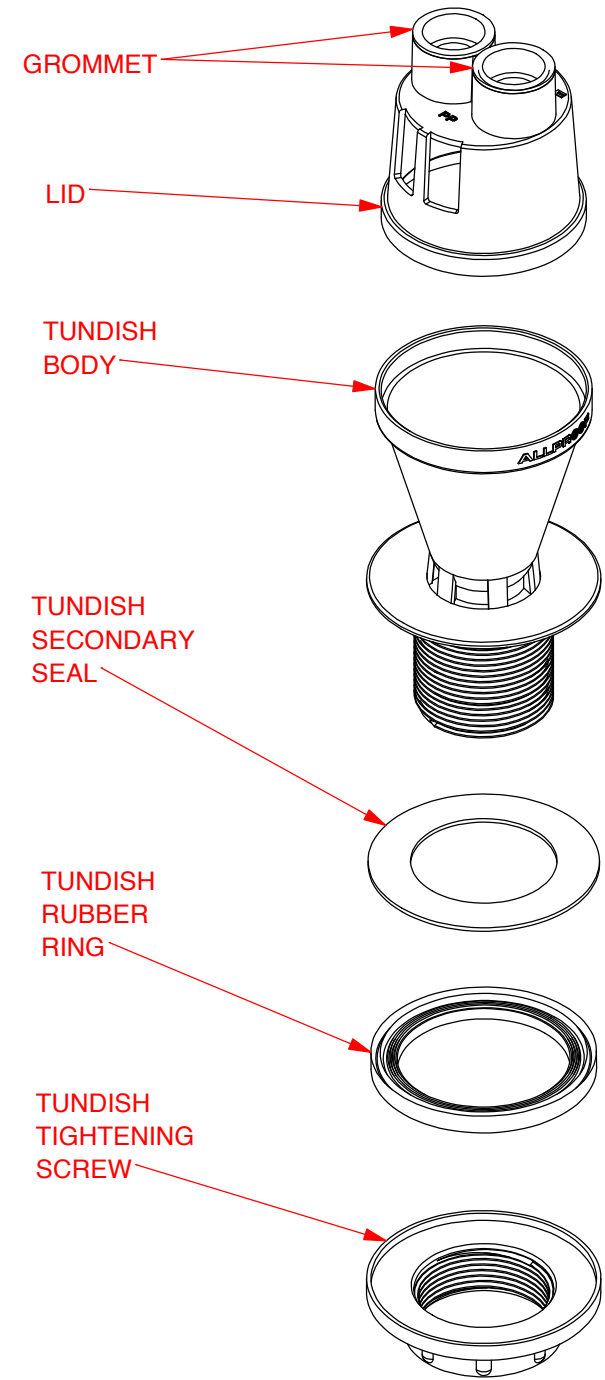

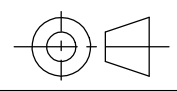
1	YES	ADDITION OF PIPE LOCATOR	SL	14.4.16
REVISION	CHANGE	DESCRIPTION	DRAWN	DATE
DO NOT SCALE DRAWING		TITLE		
REQUESTED	AJ	DATE	HOT WATER CYLINDER TUNDISH	
		14.4.2016		
DRAWN	S.L.	DATE		
		14.4.2016		
APPROVED		DATE	APPLICABLE STANDARD(S):	
MATERIAL		DRAWING REF NUMBER		
TBC		TBC		
A3	UNITS = MM	SCALE (UOS)	1:1	SHEET 1 OF 11

DISCLAIMER: THE DESIGN SUGGESTION IS PROVIDED FOR EVALUATION PURPOSES ONLY. IT IS NOT TO BE CONSIDERED A FULL DESIGN AS WE ARE NOT THE CONSULTING ENGINEERS. WE ARE MANUFACTURERS. WE ARE NOT PRIVY TO ALL THE INFORMATION PERTAINING TO THIS MATTER AND WE HAVE NO CONTROL OVER THE PROJECT INSTALLATION OF THE PRODUCT. THE DESIGN SUGGESTION IS PROVIDED WITHOUT OBLIGATION. DESIGN IS TO BE CONFIRMED AND APPROVED BY THE ARCHITECT, HYDRAULICS ENGINEER, OR PROJECT MANAGER. ACCURATE MEASUREMENTS SHOULD BE CONFIRMED BY THE PERSON APPROVING THE DESIGN. ALLPROOF ACCEPTS NO LIABILITY FOR THE IMPROPER USE OF THE DESIGN SUGGESTION.

TOOL NUMBER	0.0
PART WEIGHT(GRAMS)	0.0
FILE	S/CAD FILES/2015/DRAINAGE/IN/HWC_R1