

BEFORE STARTING / AVANT DE COMMENCER / VOR DEM START / PRIMA DI INIZIARE / VOORDAT U BEGINT MET

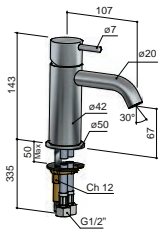

CB003C

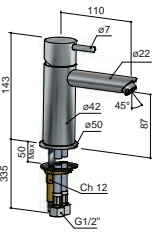

CB003S

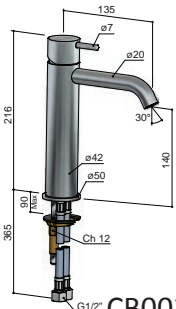

CB003MC

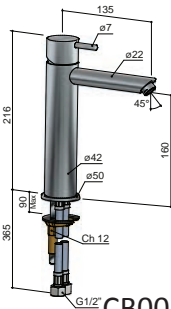

CB003MS

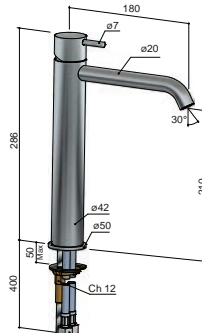

CB003HC

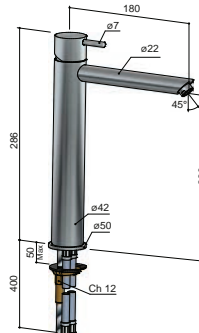

CB003HS

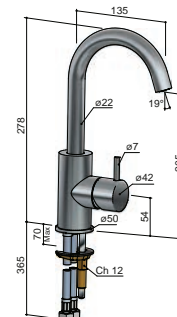

CB004

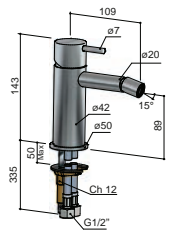

CB018

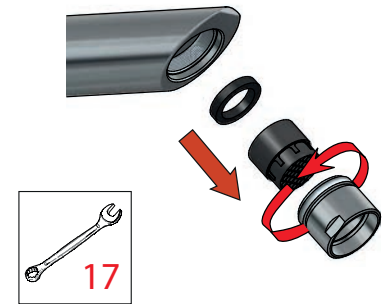
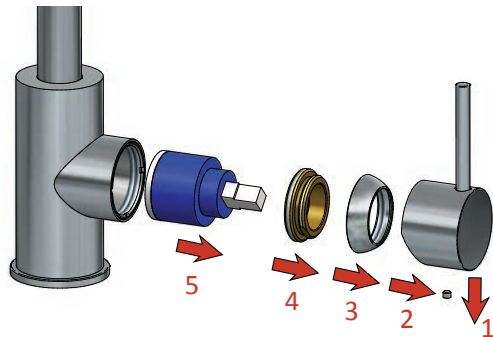
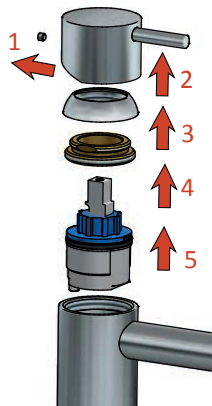
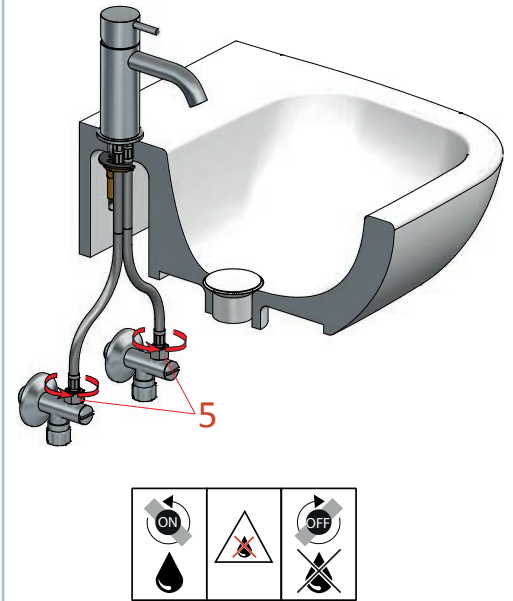
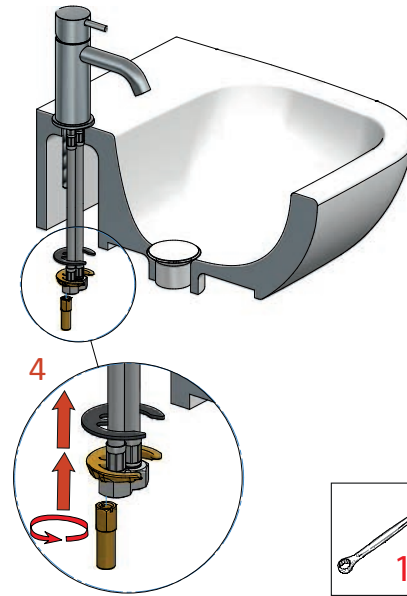
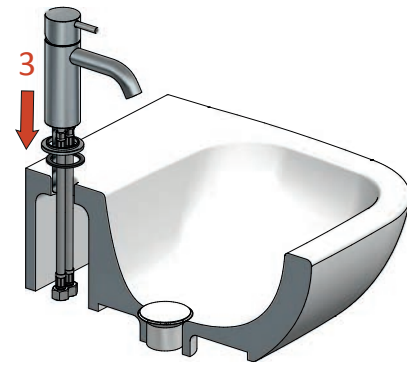
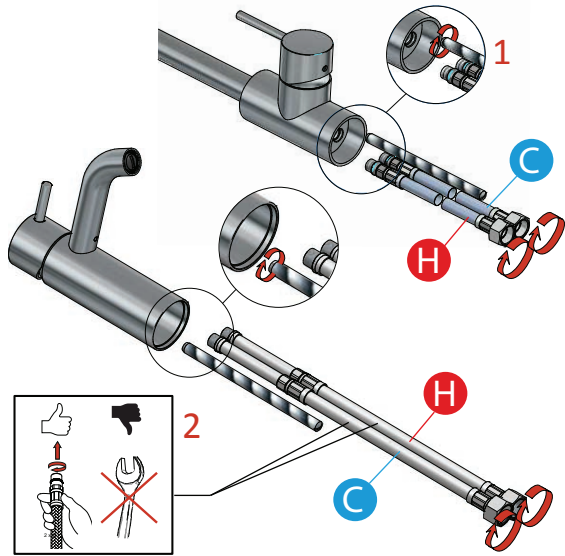

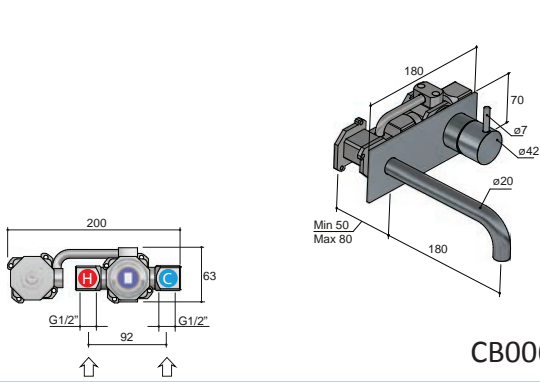

CB006

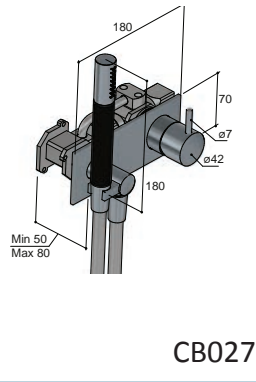

CB027

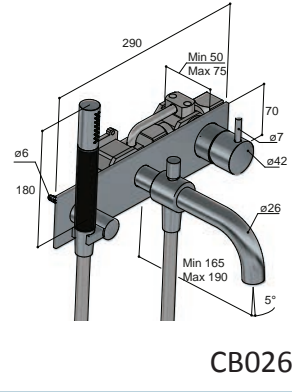

CB026

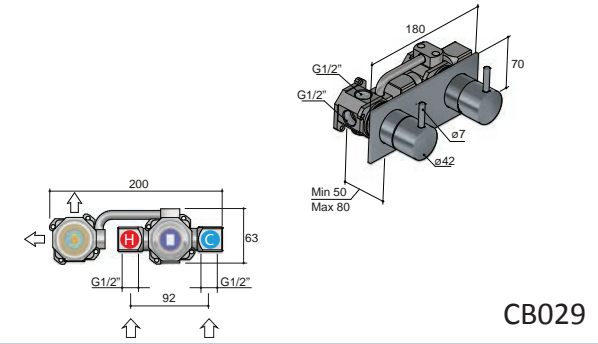

CB029

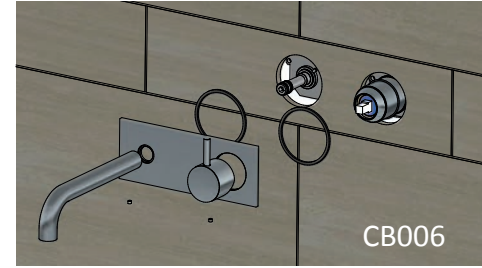
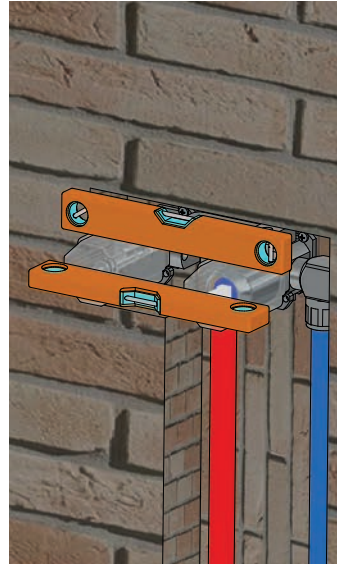
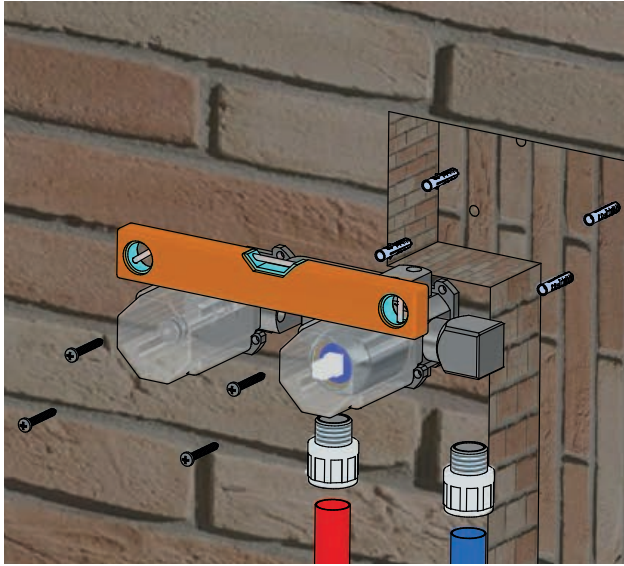

CB006

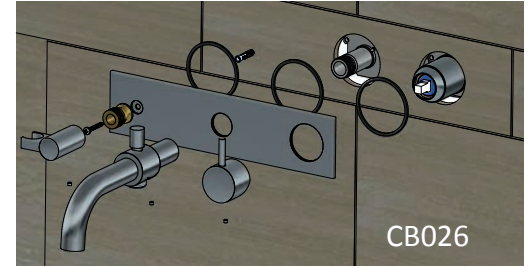

CB026

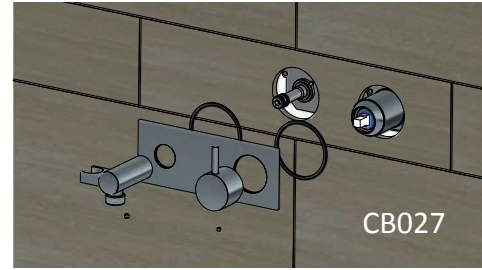

CB027

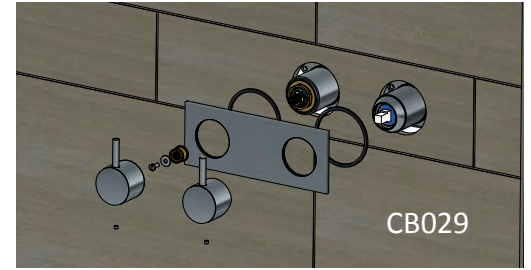

CB029

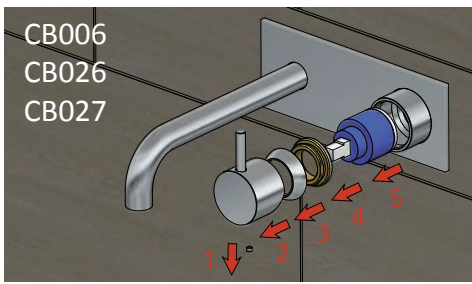

Mixer
30



MAX TIGHTENING TORQUE
10-12 Nm

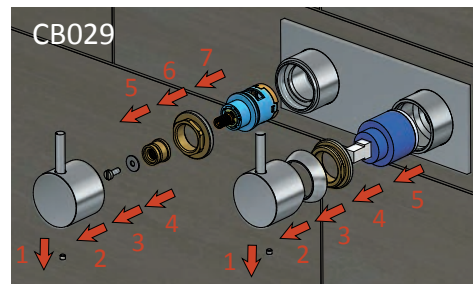

Diverter
27



MAX TIGHTENING TORQUE
14 Nm

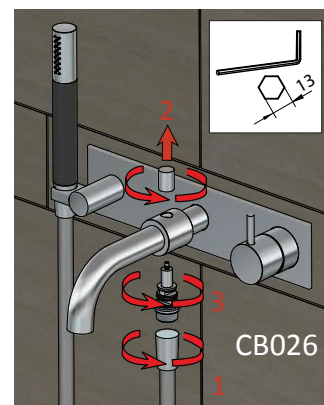

CB026



CB006



CB026

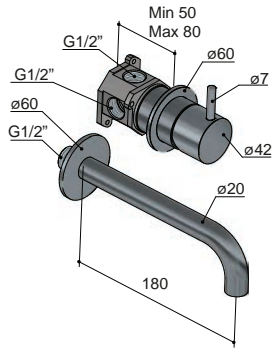

CB005

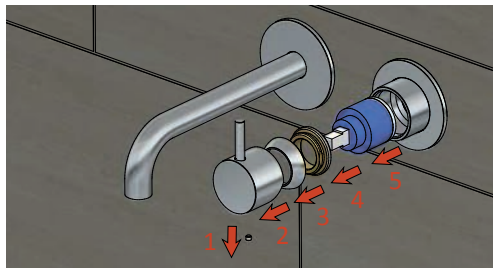
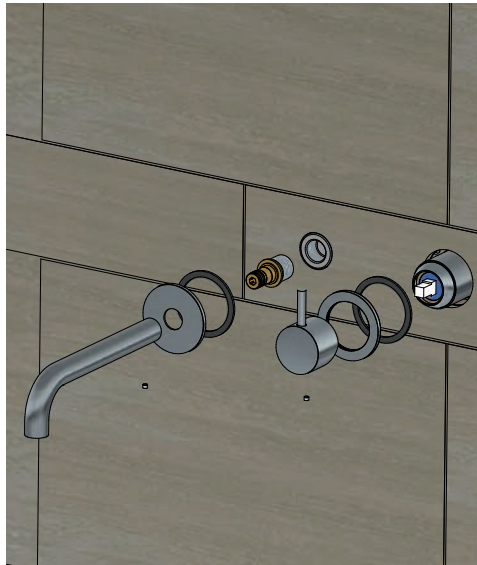
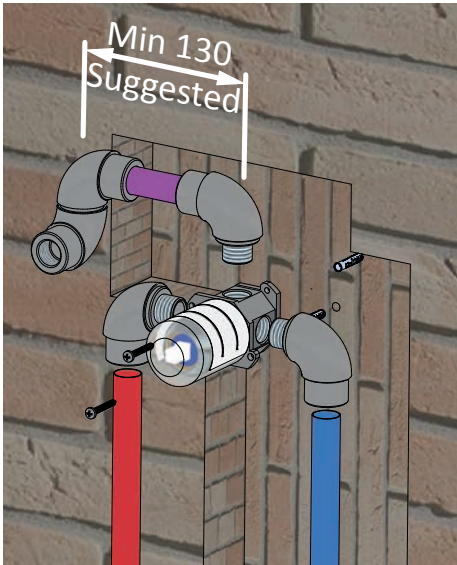

Mixer 30



MAX TIGHTENING TORQUE 10-12 Nm

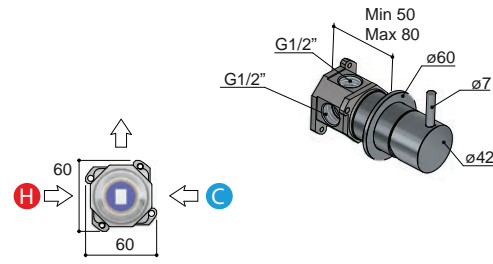

CB031

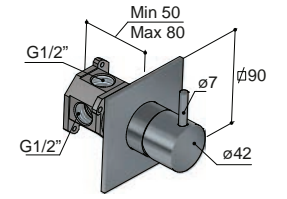

CB031Q

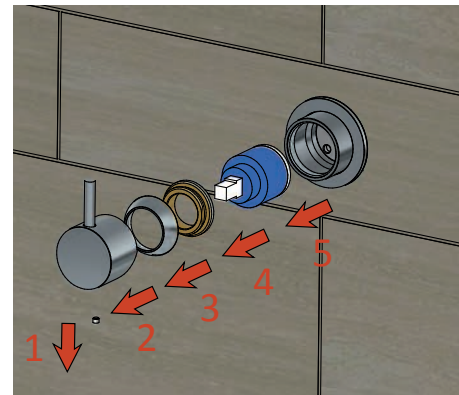
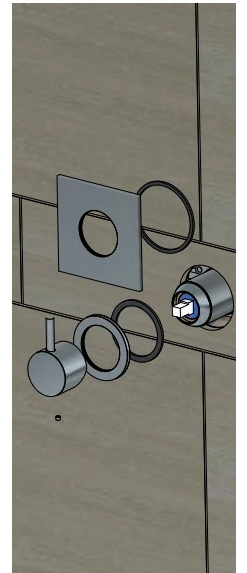
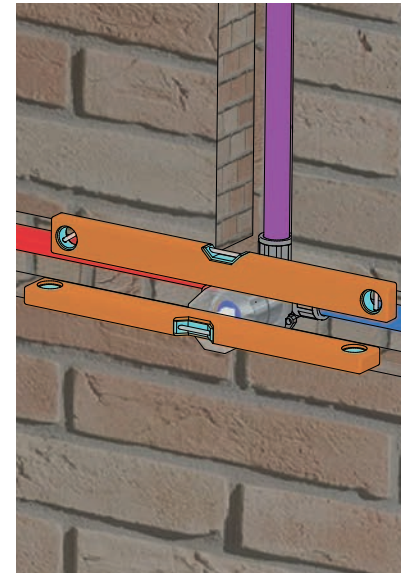
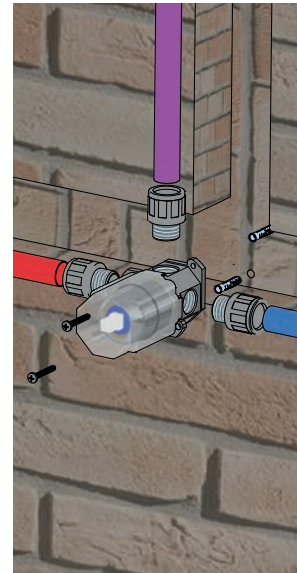

Mixer 30



MAX TIGHTENING TORQUE 10-12 Nm

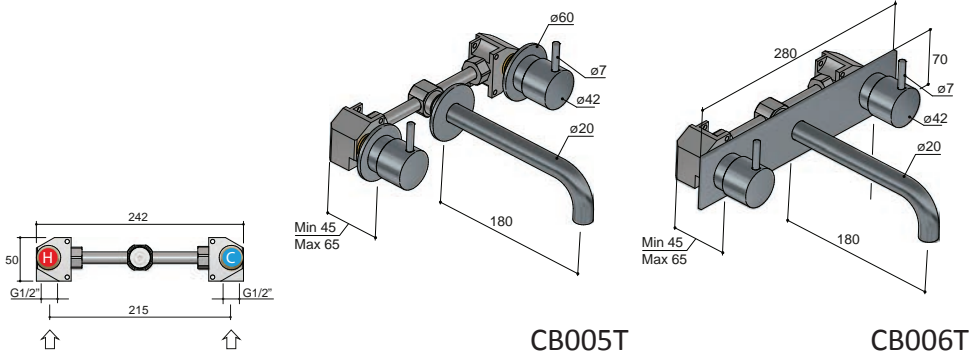

CB005T

CB006T

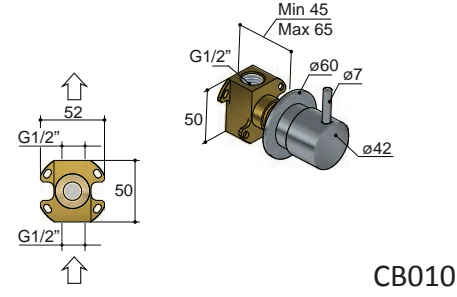
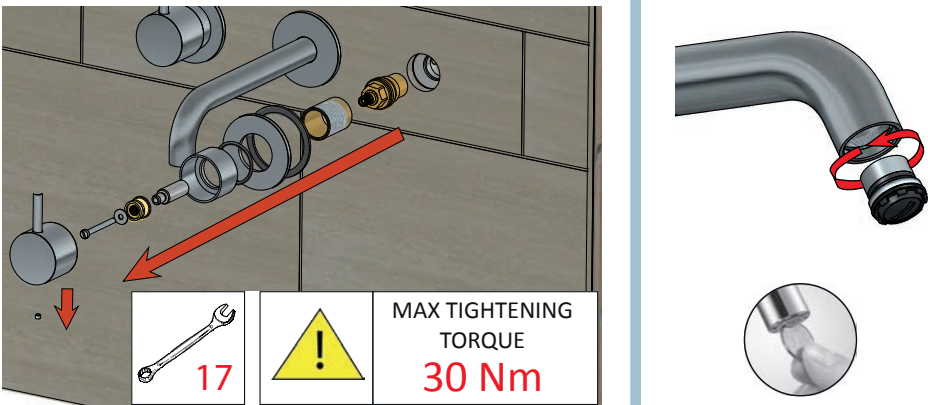
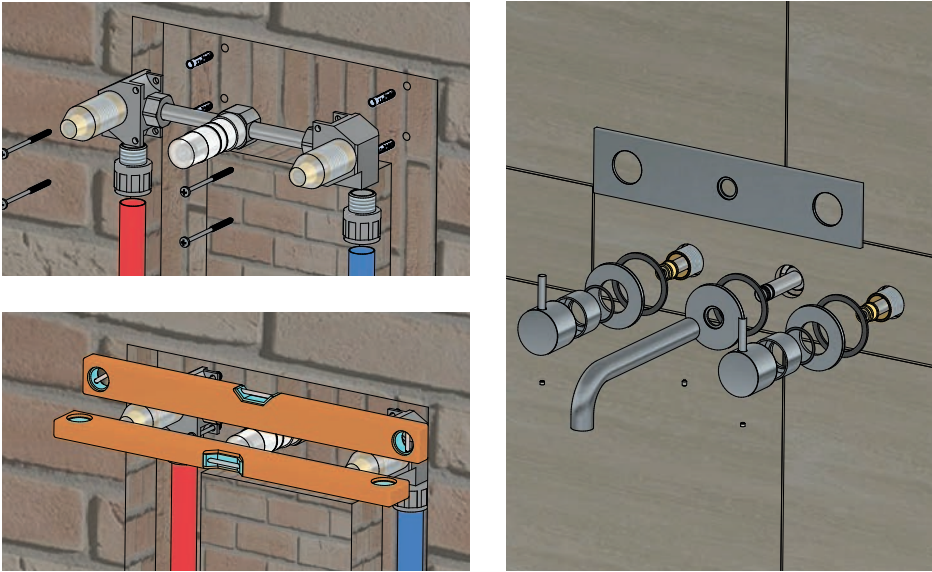

CB010

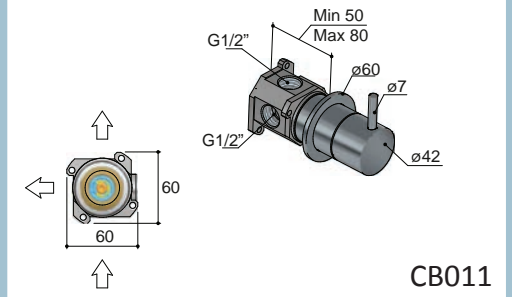

CB011

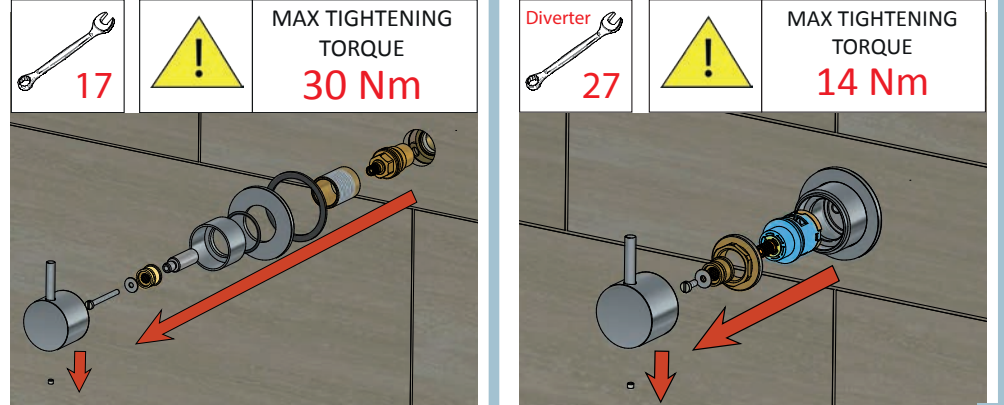
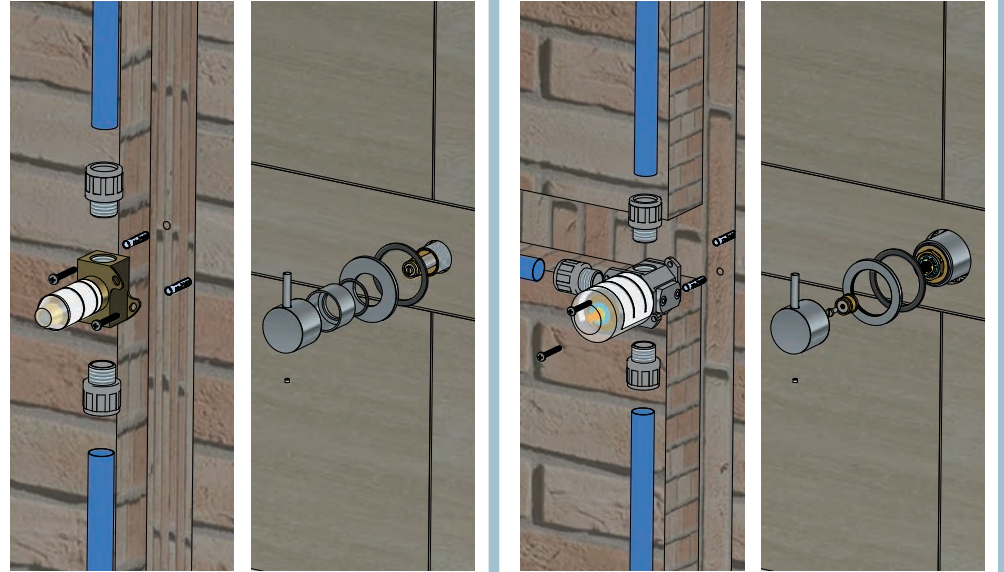

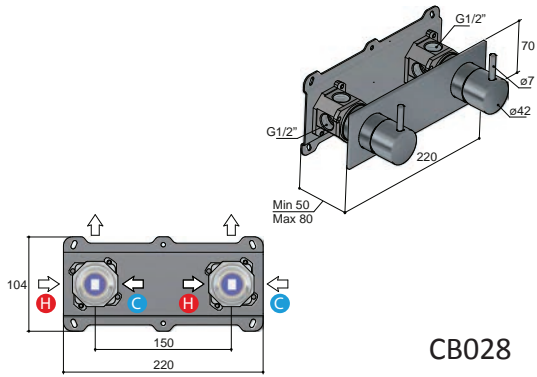

CB028

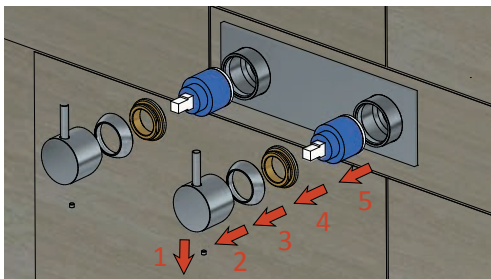
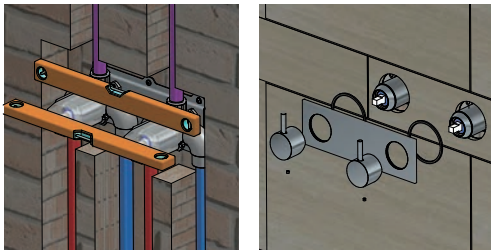
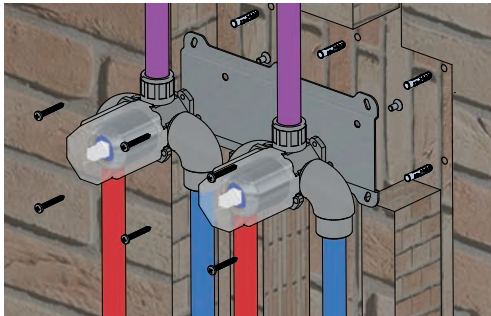

MAX TIGHTENING TORQUE
10-12 Nm

FLOOR-STANDING MIXER

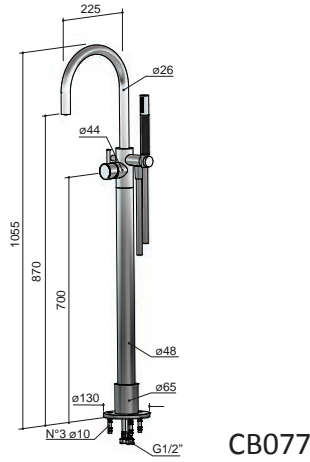

CB077

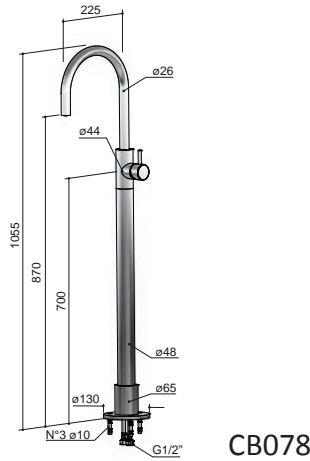

CB078

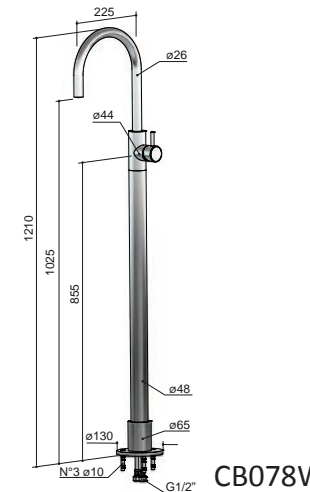

CB078W

INSTALLATION

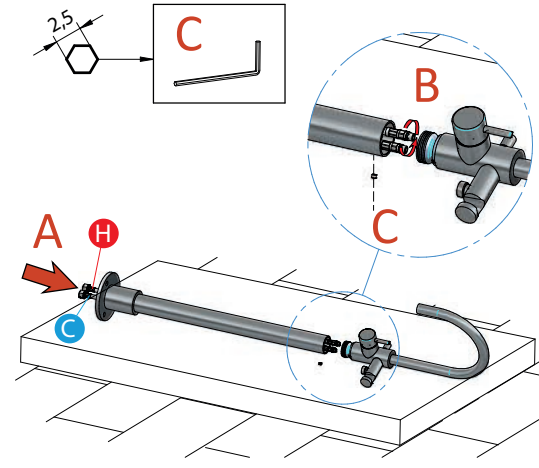

*** NOTE :**
½" TAILS OF WATER SUPPLY PIPES
MUST BE IN LINE WITH FLOOR LEVEL

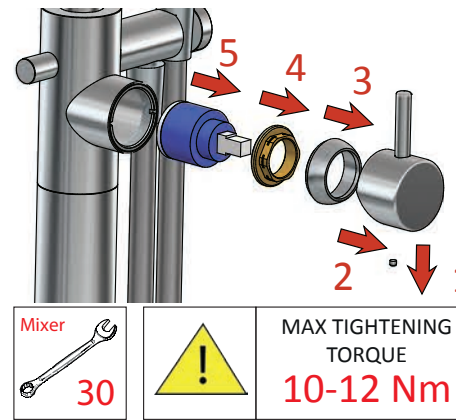
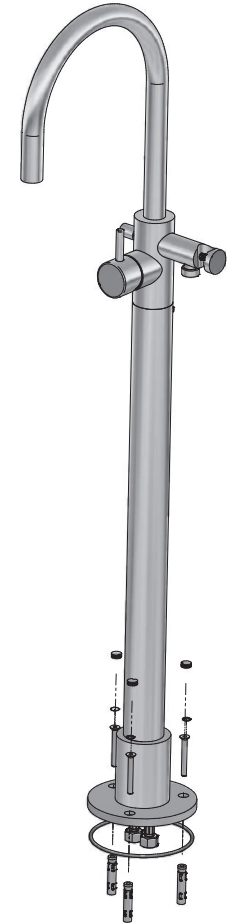
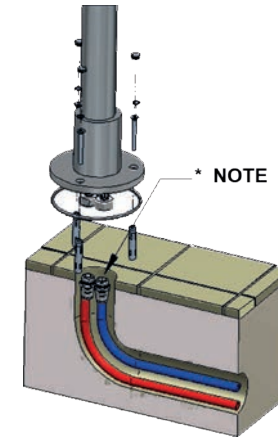





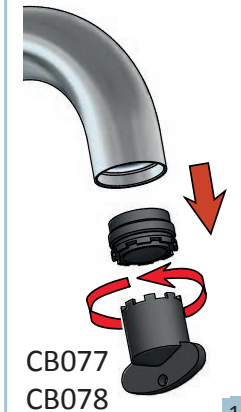































































































































MAX TIGHTENING TORQUE
10-12 Nm

CB078W



CB077
CB078

CLEANING

						WARNING
 CHROME	 WATER 	 LIQUID SOAP 	 SMOOTH CLOTH 	 ABRASIVE SPONGE 	 ACID/ABRASIVE DETERGENT 	Inoxidable plated finish
 BRUSHED NICKEL	 WATER 	 LIQUID SOAP 	 SMOOTH CLOTH 	 ABRASIVE SPONGE 	 ACID/ABRASIVE DETERGENT 	Inoxidable plated finish
 BRIGHT NICKEL	 WATER 	 LIQUID SOAP 	 SMOOTH CLOTH 	 ABRASIVE SPONGE 	 ACID/ABRASIVE DETERGENT 	Oxidizable plated finish: patina will form over time
 NATURAL BRASS	 WATER 	 LIQUID SOAP 	 SMOOTH CLOTH 	 ABRASIVE SPONGE 	 ACID/ABRASIVE DETERGENT 	Natural metal finish: patina will form over time
 BRUSHED BRASS	 WATER 	 LIQUID SOAP 	 SMOOTH CLOTH 	 ABRASIVE SPONGE 	 ACID/ABRASIVE DETERGENT 	Natural metal finish: patina will form over time
 AGED BRASS	 WATER 	 LIQUID SOAP 	 SMOOTH CLOTH 	 ABRASIVE SPONGE 	 ACID/ABRASIVE DETERGENT 	Aged metal finish: patina can form over time
 MATT WHITE	 WATER 	 LIQUID SOAP 	 SMOOTH CLOTH 	 ABRASIVE SPONGE 	 ACID/ABRASIVE DETERGENT 	Varnished finish: subject to surface scratches if not properly treated
 BRUSHED COPPER	 WATER 	 LIQUID SOAP 	 SMOOTH CLOTH 	 ABRASIVE SPONGE 	 ACID/ABRASIVE DETERGENT 	Oxidizable plated finish: patina will form over time
 ROSE GOLD	 WATER 	 LIQUID SOAP 	 SMOOTH CLOTH 	 ABRASIVE SPONGE 	 ACID/ABRASIVE DETERGENT 	Plated finish: subject to surface scratches if not properly treated
 MATT BLACK	 WATER 	 LIQUID SOAP 	 SMOOTH CLOTH 	 ABRASIVE SPONGE 	 ACID/ABRASIVE DETERGENT 	Varnished finish: subject to surface scratches if not properly treated
 AGED IRON	 WATER 	 LIQUID SOAP 	 SMOOTH CLOTH 	 ABRASIVE SPONGE 	 ACID/ABRASIVE DETERGENT 	Plated finish: subject to surface scratches if not properly treated
 BLACK CHROME	 WATER 	 LIQUID SOAP 	 SMOOTH CLOTH 	 ABRASIVE SPONGE 	 ACID/ABRASIVE DETERGENT 	Plated finish: subject to surface scratches if not properly treated