

Lia



 ITALIAN TAPWARE

Multi Function Mixer Tap System Features & Specification



- A kettle and mixer-tap combined
- Filtered near-boiling, standard hot & filtered cold water
- Simple installation easily replaces your existing tap
- Easy-grip hot water lever
- High quality DZR Brass
- Elegant one-piece design
- Smooth laminar flow
- An efficient use of space in your kitchen
- Easy to install
- Complete installation kit supplied
- WaterMark certified
- WELS certified
- 5-year warranty

 MAINS WATER PRESSURE REQUIRED



in sinkerator

multitapTM

Lia

Multi Function Mixer Tap System

FEATURES

- Easy-grip hot water handle
- High quality DZR Brass
- Elegant one piece design
- Smooth laminar flow
- Efficient, space and time saving
- Easy to install
- Complete installation kit
- WaterMark certified
- 5 year warranty



Product Code: MTLIA-CH
Finish: CHROME

Product Code: MTLIA-JB
Finish: BLACK/CHROME

Product Code: MTLIA-BR
Finish: BRUSHED

SPECIFICATIONS

- Near-boiling filtered hot water instantly.
- Safe, filtered hot water.
- Elegant swiveling spout.
- Tap insulated from heat.
- Tap available in Chrome, Black & Chrome.
- Gentle touch, lever dispenser, with safety mechanism.
- Tap mounted on either the kitchen work surface or sink. (35mm-38mm drilled hole required in the bench-top)
- Reduces chlorine, lead, and other unpleasant tastes, chemicals and odours from the water.
- Easy to install 2.5 litre stainless steel tank fitted under sink.
- Plugs directly into 240v electrical socket close to appliance.
- Adjustable temperature display on tank.
- Shut-off valve in filter head automatically stops water flow.
- Required supply pressure: 172–862 kPa (1.7–8.6 bar) (25–125 psi)
- Easy to replace filter.
- 5 Year In-Home Parts and Service Warranty
- Filtration System - 1 Year Warranty (excluding replacement filter cartridge)



Easy to install under sink tank & water filter

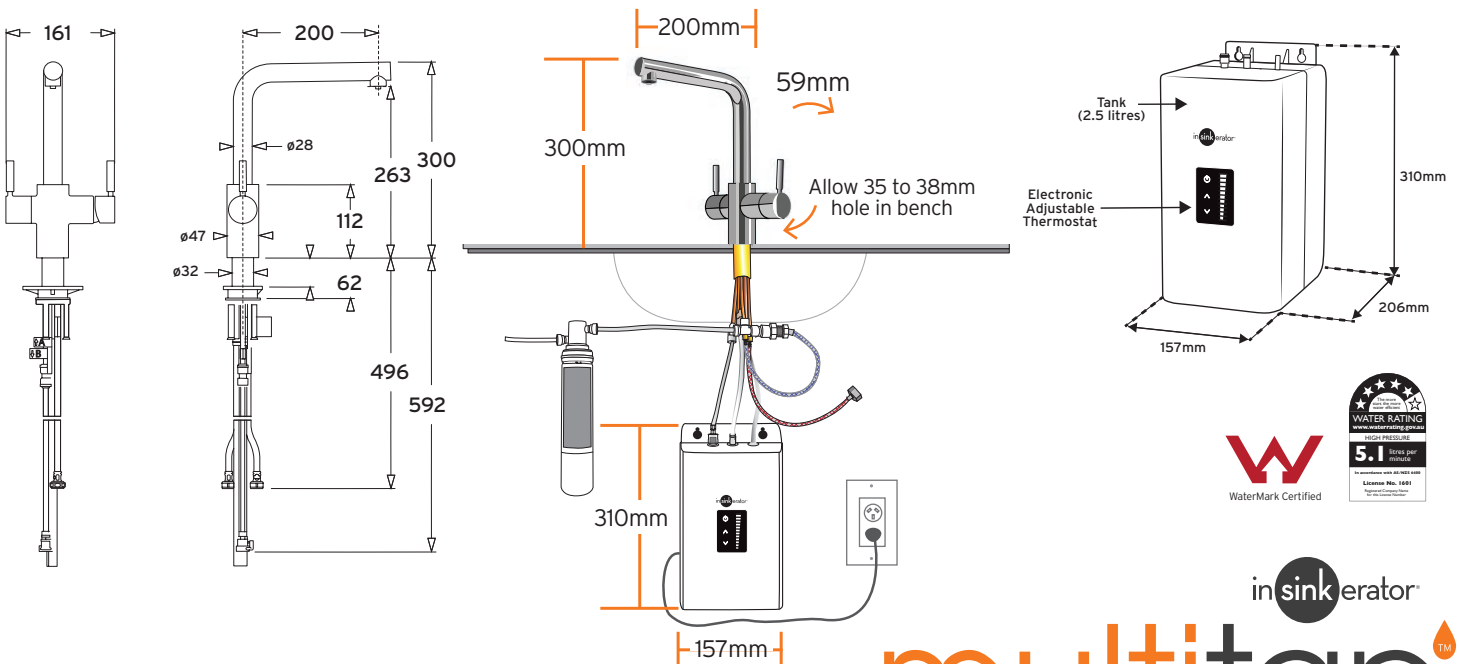

For more information contact Parex Industries Limited on Tel: 0800 200 510 or email: info.parex@emerson.com
InSinkErator reserves the right to change product specifications without prior notice.

inSinkErator
multitap