



User Guide

tastic

LUMINATE[®]

Model: 31411 Luminare Single White

Model: 32411 Luminare Dual White

Model: 31412 Luminare Single Silver

Model: 32412 Luminare Dual Silver

Electrical Rating: 230~240 V. 50 Hz.

www.ixlappliances.com.au

www.ixlappliances.co.nz

Tastic®

Welcome

Thank you for buying this IXL Tastic Luminare.

Even if you have used a Tastic before, there are very good reasons to read this user guide before using this one:

- You and your family, property and home will be safe from harm.
- You will learn how this appliance may differ from others.
- By using the Tastic Luminare fully and properly, you will get maximum life and value from it.
- Our warranty depends on you using the Tastic Luminare according to this user guide.
It will only take you a few minutes, so please read on!

Contents

Tastic Luminare Range	Pg 4-5
Safety	Pg 6
How it Works	Pg 7
Ventilation Requirements	Pg 8
Overview	Pg 8
Wall Switch Operation	Pg 9
Removing Glass Shield	Pg 10
Heat Lamp Replacement	Pg 11
LED Replacement	Pg 12
Replacement Lamps	Pg 13
Cleaning & Maintenance	Pg 13
Frequently Asked Questions (FAQs)	Pg 14
Products	Pg 15
Warranty	Pg 16-17
Warranty Registration	Pg 18



31411 Luminate Single – White

1 x 800 W Tungsten Halogen Heat Lamps
25W LED - Warm / Cool
Plug & Play Wall Switch
Cutout Template Supplied
170 mm Exhaust Fan,
480 m³/hr or 133 l/s
150mm x 6m Duct Supplied



32412 Luminate Single – Silver

1 x 800 W Tungsten Halogen Heat Lamps
25W LED - Warm / Cool
Plug & Play Wall Switch
Cutout Template Supplied
170 mm Exhaust Fan,
480 m³/hr or 133 l/s
150mm x 6m Duct Supplied

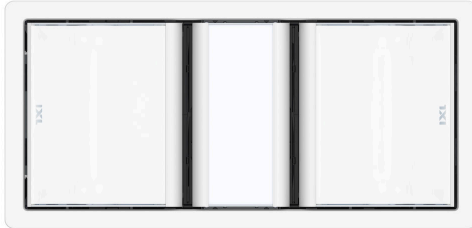

32411 Luminate Dual
– White

2 x 800 W Tungsten Halogen Heat Lamps
 25W LED - Warm / Cool
 Plug & Play Wall Switch
 Cutout Template Supplied
 170 mm Exhaust Fan,
 480 m³/hr or 133 l/s
 150mm x 6m Duct Supplied



32412 Luminate Dual
– Silver

2 x 800 W Tungsten Halogen Heat Lamps
 25W LED - Warm / Cool
 Plug & Play Wall Switch
 Cutout Template Supplied
 170 mm Exhaust Fan,
 480 m³/hr or 133 l/s
 150mm x 6m Duct Supplied

Read through these instructions completely before commencing installation.



- **When installed, the Tastic Luminate appliance shall, under no circumstance, be covered with insulating material or similiar material.**
- **This Tastic unit must be installed horizontally in the ceiling.**
- **There is no IP rating on these IXL Tastic Luminate models.**
- **To prevent overheating do not place any object within 1 metre of heat lamps.**

NOTE: This product must be installed by a qualified installer.

Locate the Tastic in accordance with the requirements of the current Australian/New Zealand Wiring Rules AS/NZS 3000 relating to damp situations.

In some installations this may mean that no part of these Tastic may be located directly above any part of a bath or shower recess or enclosure. For unenclosed showers refer to Wiring Rules conditions. Switches and other controls must not be located where they can be touched by a person in the bath or shower.

- Do not look directly into heat lamps when in use.
- Tastic products are not tanning lamps.
- Make sure the lamps have cooled and power is off to the Tastic before removing lamps for replacement.
- Do not operate this appliance without the fascia or glass panels in position.
- This appliance is not intended for use by persons (including children) with reduced physical, sensory or mental capabilities, or lack of experience and knowledge, unless they have been given supervision or instruction concerning use of the appliance by a person responsible for their safety.
- Young children should be supervised to ensure they do not play with the appliance.
- This appliance must be mounted with the lowest point at least 2.2 metres from the floor.
- If the supply cord is damaged, it should be replaced by the IXL Home or its service agent or a similarly qualified person in order to avoid a hazard.
- This appliance must not be mounted immediately below a socket outlet.
- Regulations concerning the discharge of air have to be fulfilled.

WARNING: Curtains or combustible material may ignite if in contact or close proximity with the heater.

Thermal Switch

When Tastic Luminate heat lamps are operating and the fan is off, if the temperature inside the unit reaches 55°C, the built-in thermal switch will switch on the fan automatically. When the temperature drops, the thermal switch will switch off the fan.

Over-temperature switch (PTCR)

If for any reason the temperature inside the Tastic Luminate reaches 80°C, The PTCR will cut off power to the unit. The PTCR can be reset by turning off power to the unit at the isolating switch and allowing to cool for 10-15 minutes.

In such a case the Service Centre should be called as this is not normal operation.



In order to avoid a hazard due to inadvertent resetting of the thermal cut out, this appliance must not be supplied through an external switching device, such as a timer, or connected to a circuit that is regularly switched on and off by the utility.

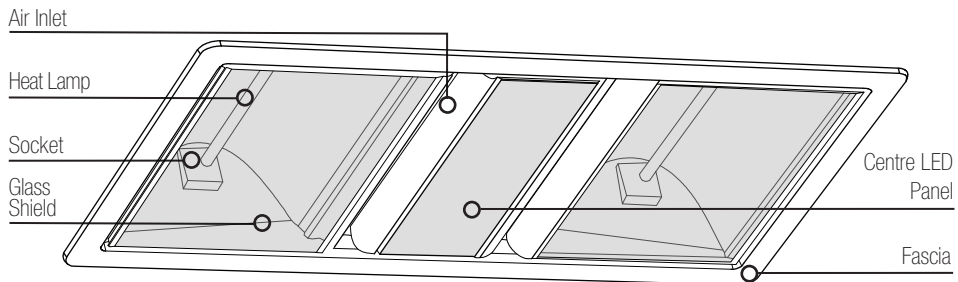

How it works

Tastic Luminate range has been designed to exacting standards to give you many years of trouble-free operation. To ensure you get the most from your Tastic there are a few simple points to keep in mind.

Heat Lamps

The IXL Tastic Luminate uses 800W tungsten halogen heat lamps in conjunction with reflective elements, for a more efficient dispersion of radiant heat. The tungsten halogen lamps provide instantaneous heat, and are designed to heat you and not your bathroom - that's the efficient way infra red heat works. To get the full benefit of Tastic's tungsten halogen warmth, stand directly under the heat lamps. IXL's exclusive halogen lamps have been designed specifically for this application, and concentrate their heat for maximum effectiveness. Make sure you have the Tastic model that suits your bathroom ceiling height. This Tastic is manufactured to offer peak performance with bathroom ceiling heights up to 3.3m. The Luminate has the additional energy saving feature of a timer which will turn off the heat lamps after 1 hour.

Centre LED Panel

The LED panel in Tastic Luminate is designed to provide room lighting in your bathroom and can be operated in either cool(4000K) or warm(3000K) light modes.

In order to ensure long life of the LED panel, it will not operate while any heat lamps are switched on.

If the heat lamps are switched on while the LED panel is on, the LED panel will automatically turn off. When the heat is turned off the LED will automatically turn back on again.

Ventilation

IXL Tastic Luminate utilises a high performance ducted fan to draw steam out of your bathroom and vent it directly outside.

To allow the Tastic's efficient exhaust fan to remove steam while you shower, it is essential that there is adequate air flow into your bathroom through windows, vents or under the door.

The air flow path from inlet to fan should ideally pass over the steam source. Bathrooms which have high ceilings, are larger than average, or have an open shower may all require an additional ventilation fan. We recommend that you visit our website for further details and suggestions on effectively ventilating your bathroom.

Ventilation Requirements

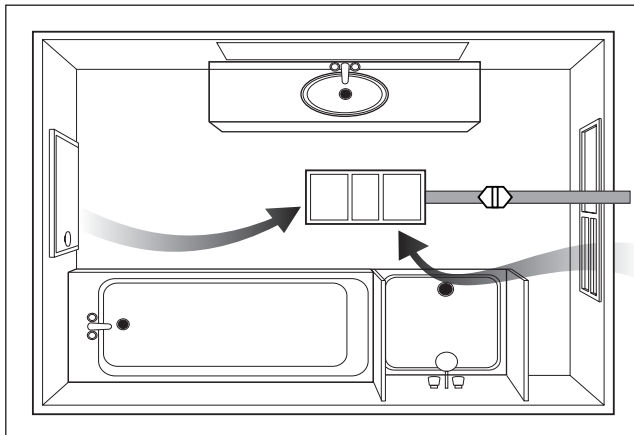

Fig. 1: Ideal placement of Tastic. Sufficient air inlets into room are required

Overview

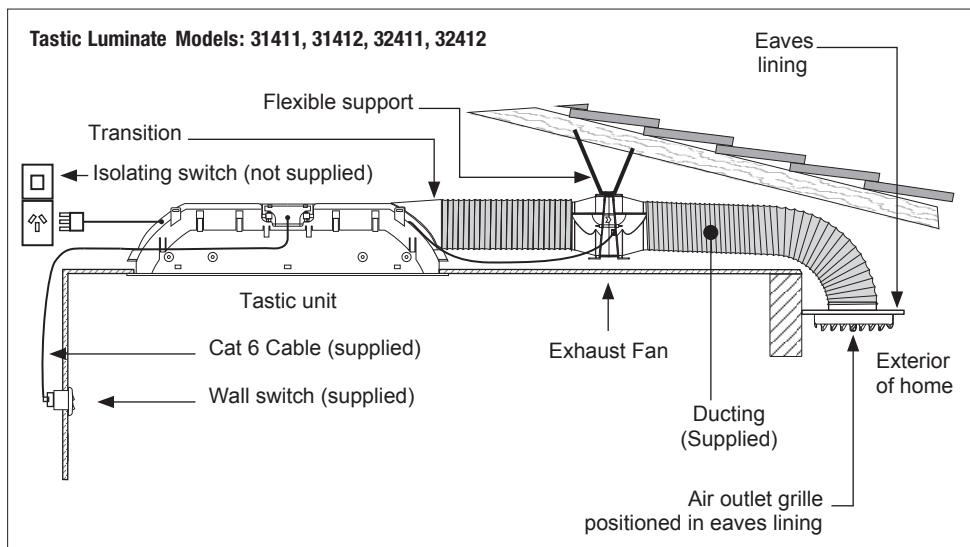

Fig. 2: Layout of Tastic Luminate Single and Dual.

Plug & Play Wall Switch System & functions

All functions are controlled by the custom Tastic Luminate wall switch (Fig. 3).
Connected to the main unit by Cat 6 cable (supplied)

NOTE: While the heat lamps are turned **ON**, the centre LED Light is automatically turned **OFF**.

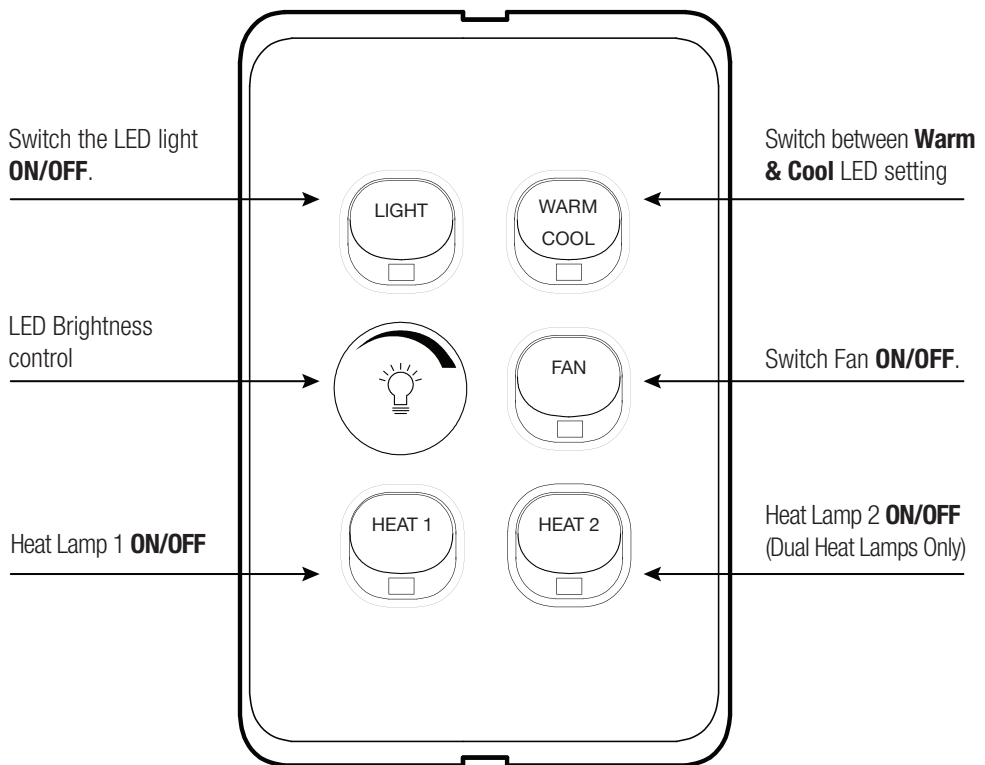

Fig. 3

Preparing

Turn the heat lamp off and let it cool for at least 5 minutes. For extra safety, switch the power off at the isolating switch. Position a sturdy ladder of sufficient height to let you safely and comfortably reach the Tastic Luminate. Ask someone to hold the ladder if you can.

Removing Glass Shield

With one hand gently press the glass shield (at a point close to the air inlet) 20 mm towards the ceiling and carefully slide it towards the air inlet.

Hold your other hand below the other end of the shield to catch it when it drops.

If the shield chips, cracks or breaks replace it with IXL Tastic® Luminate Tempered Glass Shield (Part 12200), not normal household glass. Do not operate the heat lamp without the glass shield in place.

Step 1.

Push up inner edge of glass

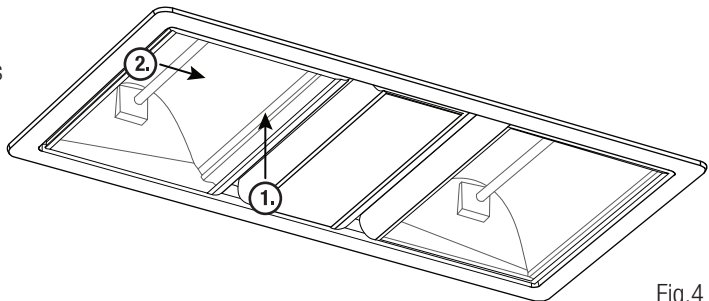

Fig.4

Step 2.

Slide glass across

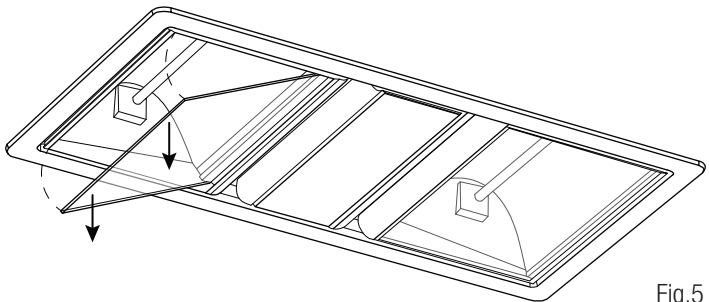

Fig.5

Step 3.

Glass drops down

Removing Old Heat Lamp

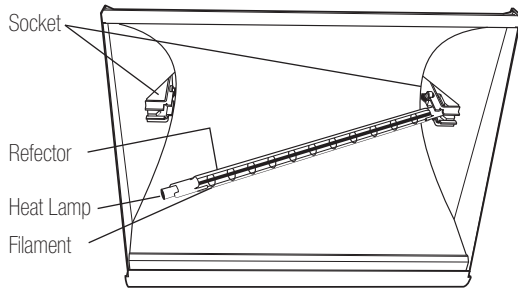

Fig. 6

A spring-loaded socket holds each end of the heat lamp. Gently grasp the heat lamp and push it towards one socket. When it is free of the other socket, carefully pull the heat lamp down towards you.

The heat lamp is not recyclable. Dispose of it like a normal incandescent light globe (i.e. unbroken, with your general waste, wrapped in any paper or cloth you used).

Fitting New Heat Lamp

Natural skin oils and salts damage new halogen lamps and shorten their life. Only handle a new heat lamp with soft, dry, clean, lint-free cloth or paper. You can wear gloves, cover your fingers or wrap the heat lamp until it is installed (so long as you remove all cloth or paper when finished).

If your skin touches a new heat lamp, wipe it gently with alcohol-moistened cloth or paper.

The heat lamp is half coated with a white reflector. When you grasp the heat lamp, face the back of the reflector to the ceiling (so you can see the heat lamp's filament). Not doing this will reduce performance.

- Fit one end of the heat lamp into a socket and gently push it away from the other socket.
- When there is enough room, fit the other end of the heat lamp into its socket.
- Gently rotate the heat lamp to ensure it is correctly seated (i.e. it looks like the old one did before you removed it).
- Replace the glass shield by reversing the directions for removing it.
- Switch the power on and test the heat lamp.

In the unlikely event that your LED panel requires removal/replacement, follow the steps below:

Note: Position a sturdy ladder of sufficient height to let you safely and comfortably reach the Tastic Luminate. Ask someone to hold the ladder if you can.

Step 1.

Remove Fascia

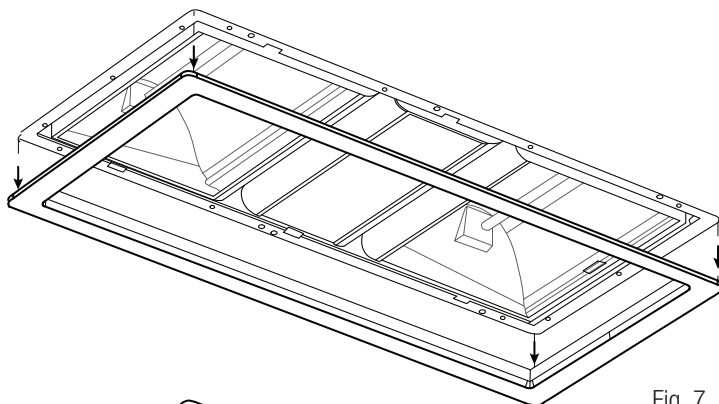

Fig. 7

Step 2.

Unscrew mounting screws

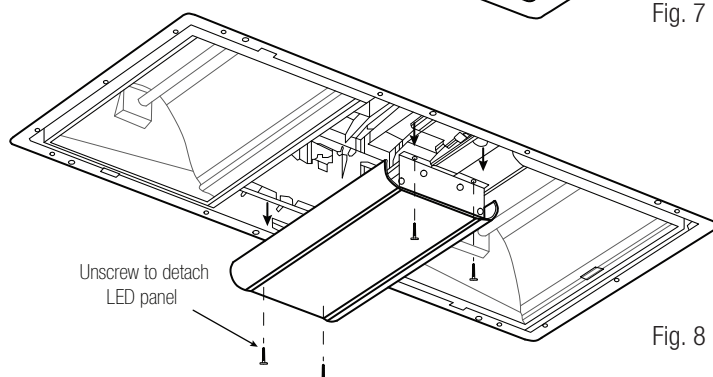

Fig. 8

Step 3.

Unplug cable

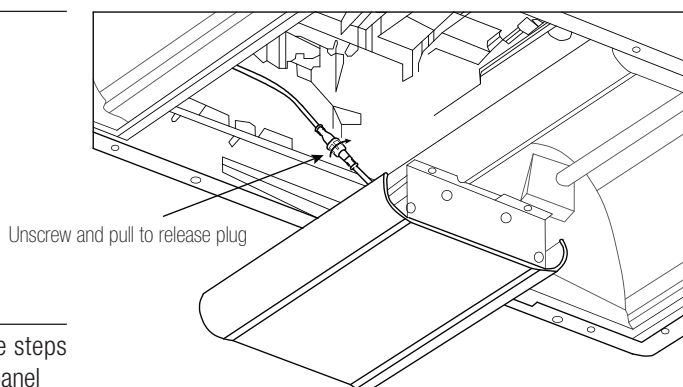

Fig. 9

Step 4.

Reverse the above steps to install the LED panel

NOTE: Replacement with any other lamps other than those listed below may cause damage to the Tastic Luminate and void the warranty.

Heat Lamps

The IXL Tastic lamps have been specially developed for best performance.
R7s, 800W max. IXL Cat No. 11380

NOTE: Replace only with genuine IXL approved infra red halogen heat lamps.

LED Panel

The Tastic Luminate LED is only available from IXL Home.
Please contact IXL Home for stocklist.

Cleaning & Maintenance

WARNING: Always make sure the unit is turned off and allow all lamps to cool before cleaning.

Maintenance of the Tastic Luminate is required to ensure the quality of the product and functions are maintained.

It is recommended that the Tastic Luminate body, fascia and lamps be checked and cleaned every 2 years. To clean the fascia and air inlet use a damp cloth with liquid glass cleaner. Cleaning and maintenance will help to preserve the life-span and performance of the Tastic Luminate.

Note: Position a sturdy ladder of sufficient height to let you safely and comfortably reach the Tastic Luminate. Ask someone to hold the ladder if you can.

Service

NOTE: Do not remove the Tastic Luminare from the ceiling. Your Tastic Luminare will be serviced in your home. If service is required, please contact IXL Home.

Frequently asked questions

Q – Will my Tastic Luminare heat my bathroom?

A – No, your Tastic Luminare is designed to provide infra red radiant heat to warm the body when standing directly underneath. It is not designed as a room heater.

Q – Can I install my Tastic Luminare directly above a shower recess?

A – For safety reasons it is not permitted to install above shower recess. Please refer to the current Australian/New Zealand Wiring Rules AS/NZS 3000 relating to damp situations for further details.

Q – What will happen if I leave my heat lamps on without fan operation?

A – The fan will commence operation automatically to keep the unit operating at a safe temperature. When the unit has cooled sufficiently the fan will switch off automatically.

Q – Why is my Tastic Luminare making noise?

A – All Tastics create some noise due to the rapid movement of air through the Tastic. You may also notice a ticking noise as the unit heats or cools from operating the heat lamp.

Q – Can the installer rotate the IXL wall switch mechanisms?

A – Yes, the wall switches can be rotated by a qualified electrical trades person without modifying the wiring of the switch.

Q – Can my installer use an alternative wall switch mechanism other than the one supplied with my IXL product?

A – No, the IXL Tastic Luminare can only be operated by the custom IXL wall switch supplied with the unit.

Q - My Tastic unit's extraction fan doesn't seem to be removing all the moisture and steam from my bathroom?

A – There are a number of factors that will influence the exhaust fan's performance. Firstly you can improve your cross ventilation via an open door or window; refer to page 7 of the instructions for details on improving the room's air flow. If you live in a traditionally cooler climate, in the winter months during hot showers, you may notice that there is more moisture and condensation build up. If this is the case, you may wish to improve your natural ventilation or invest in an additional exhaust fan. Bathrooms which have high ceilings, are larger than average, or have an open shower may all require additional ventilation. We recommend that you visit our website for further details and suggestions on effectively ventilating your bathroom. Tastic Luminare is designed to suit bathrooms up to 12m².

Q - Can the Tastic Luminare duct vertically through the roof?

A – Yes, additional parts required (not supplied).

IXL Tastic Luminare Range

Within the IXL Tastic Luminare range, there are a number of products available:

- Tastic Luminare Heat Module
(model no. 36411, 36412)
- Tastic Luminare Vent Module
(model no. 35401, 35402)
- Tastic Luminare Vent & Light Module
(model no. 34401, 34402)

IXL Range: Accessories

- Genuine IXL Heat Lamps (Model no. 11380)
- In line Ducting (Model no. 10383)

For more information or help, please contact IXL Home.

Tastic Luminate by IXL Home Pty. Ltd Warranty

1. IXL Home Tastic products come with guarantees that do not exclude the following consumer entitlements under the Australian and New Zealand Consumer Law:
 - a. replacement or refund for a major failure and compensation for any other reasonably foreseeable loss or damage; and
 - b. to have the goods repaired or replaced if goods fail to be of acceptable quality and the failure does not amount to a major failure.
2. IXL Home warrants that your product and related supply will be free from defects in materials and workmanship during the warranty term. Your in home warranty term is five years with a two year replacement warranty on the heat lamps, exhaust fan & LED panel, commencing from the date of purchase. IXL Home acknowledges this product requires professional installation and product removal is hazardous to consumers, accordingly any necessary inspections and services will be carried out on site. You should not attempt de-installation.
3. Subject to Point 1, IXL Home will repair any defects in materials and workmanship during the warranty term and if the product is deemed irreparable provide a replacement of an equivalent current model where the balance of the warranty period from the original date of purchase will take effect. Also subject to Point 1, where the exhaust fan is installed into an environment that has limited access and the unit needs to be serviced or replaced under warranty, a replacement exhaust fan will be supplied free of charge by IXL Home however, all associated reinstallation charges will be borne by the owner.
4. To the fullest extent permitted by law and subject always to Point 1, IXL Home will not be liable for:
 - a. any loss or damage arising from loss of use, loss of profits or revenue; or
 - b. for any indirect or consequential loss or damage resulting from any breach of this warranty against defects.
5. Defective IXL Home Tastic products may be repaired using refurbished parts or if required, completely replaced by a refurbished product of the same type.

Limitations to Your IXL Warranty

6. Subject to Point 1, this Warranty:
 - a. will only be provided to the original purchaser where the original purchase was made from a IXL Home Authorised Dealer or Reseller and proof of such purchase can be presented at the time of service;
 - b. only applies to IXL Home Tastic products purchased in Australia and New Zealand from a IXL Home Authorised Dealer or Reseller and installed by a qualified person where a Certificate of Compliance in accordance with Country/State/Territory laws is provided;
 - c. will not apply where the defect in or failure of the product is attributable to misuse, abuse, accident or non-observation of the manufacturer's instructions. This product must be used in accordance with the manufacturer's instructions;

- d. will not cover faults due to normal wear and tear with reasonable use nor consumable components such as globes, glass items, etc;
- e. will not cover any damages or problems caused to this product by natural forces eg. storm, fire, food, and earthquake; or by intrusion or accumulation (or both) of foreign matters eg. dust, soil, and moisture. IXL Home recommends that you take out appropriate insurances to protect your product to this end;
- f. will not apply if this product is installed in a mobile dwelling eg. caravan or boat;
- g. will not apply if this product is removed from the location where it was first installed;
- h. is immediately void if the serial or model number label is removed or defaced;
- i. is immediately void if the product is serviced or repaired by a unauthorised/unqualified personnel;
- j. covers use of this product for domestic use only;
- k. will not be restarted or extended upon repair or replacement of the product or a part.

How to make a Claim under Your IXL Warranty

7. To make a claim under this Warranty you will need to:
 - a. contact IXL Customer service to provide details and register your claim enabling an assessment.
 - b. submit proof of purchase with your claim eg. tax invoice or purchase receipt;
 - c. where a property has been constructed by a builder/developer and it is fitted with IXL products, please submit proof of purchase by way of the certificate of occupancy, with your claim.
8. IXL Home will contact you to make arrangements for service on site.
9. Subject to Point 1, you will be responsible for any costs relating to the provision of your product to a IXL Home Authorised Service Dealer .
10. Subject to Point 1, in the event you live more than 50 km from a IXL Home Authorised Service Dealer you may be subject to travel or transport costs to facilitate the repairing or replacement of your IXL product.
11. IXL Home and its Authorised Service Dealers reserve the right to seek reimbursement of any costs incurred by them should your IXL product be found to be in good working order.

Privacy

The privacy of your personal information has always been important to us. To learn more about how we collect, keep and use your personal information, please obtain a copy of our privacy statement by visiting our website or by contacting us via email.



Visit IXL Home website below to register your warranty details online.

Australia

www.ixlappliances.com.au/warranty

New Zealand

www.ixlappliances.co.nz/warranty

Tastic®

Notes

For comments, questions or warranty matters:

**IXL Home Pty Ltd
Australia**

Free Call: 1300 727 421
Fax: 1300 727 425
service@ixl.com.au
www.ixlappliances.com.au

New Zealand

Free Call: 0800 727 421
service@ixlappliances.co.nz
www.ixlappliances.co.nz

© Copyright IXL Home, 2018



Approved by the appropriate electrical supply authorities.

Part number 611055_A