

DESCRIPTION	
CODE	FINISH
LOB SML	PLASTIC
159.40	PLASTIC

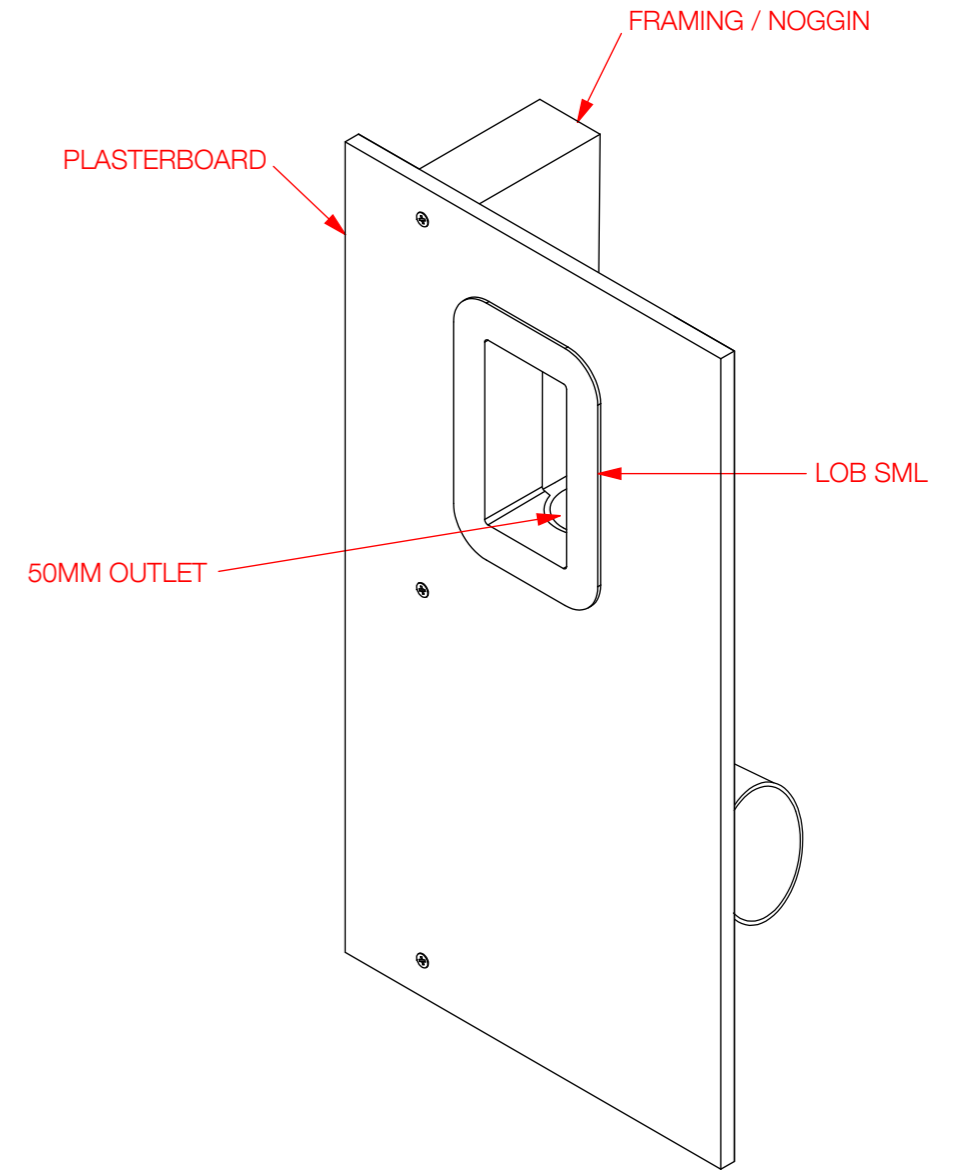
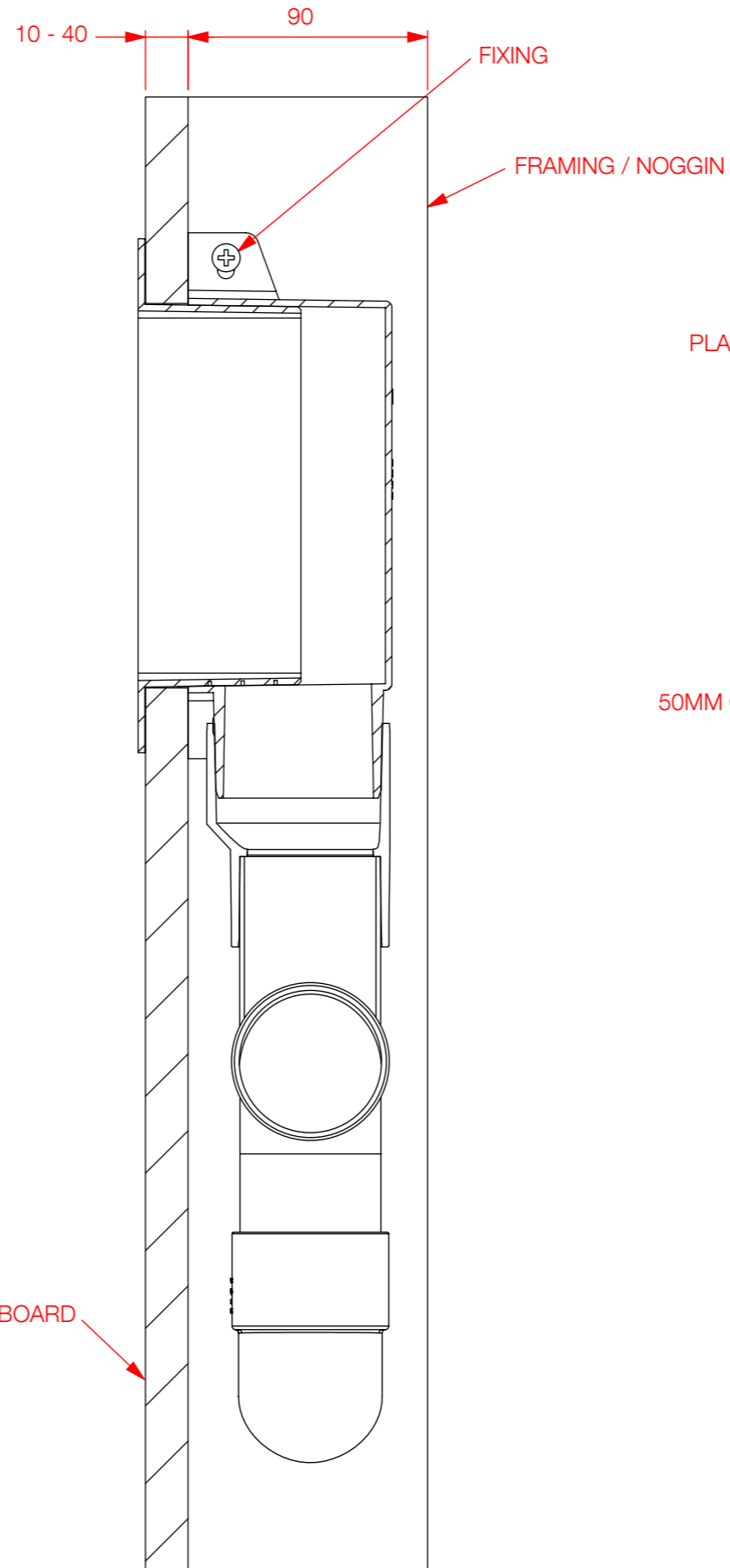
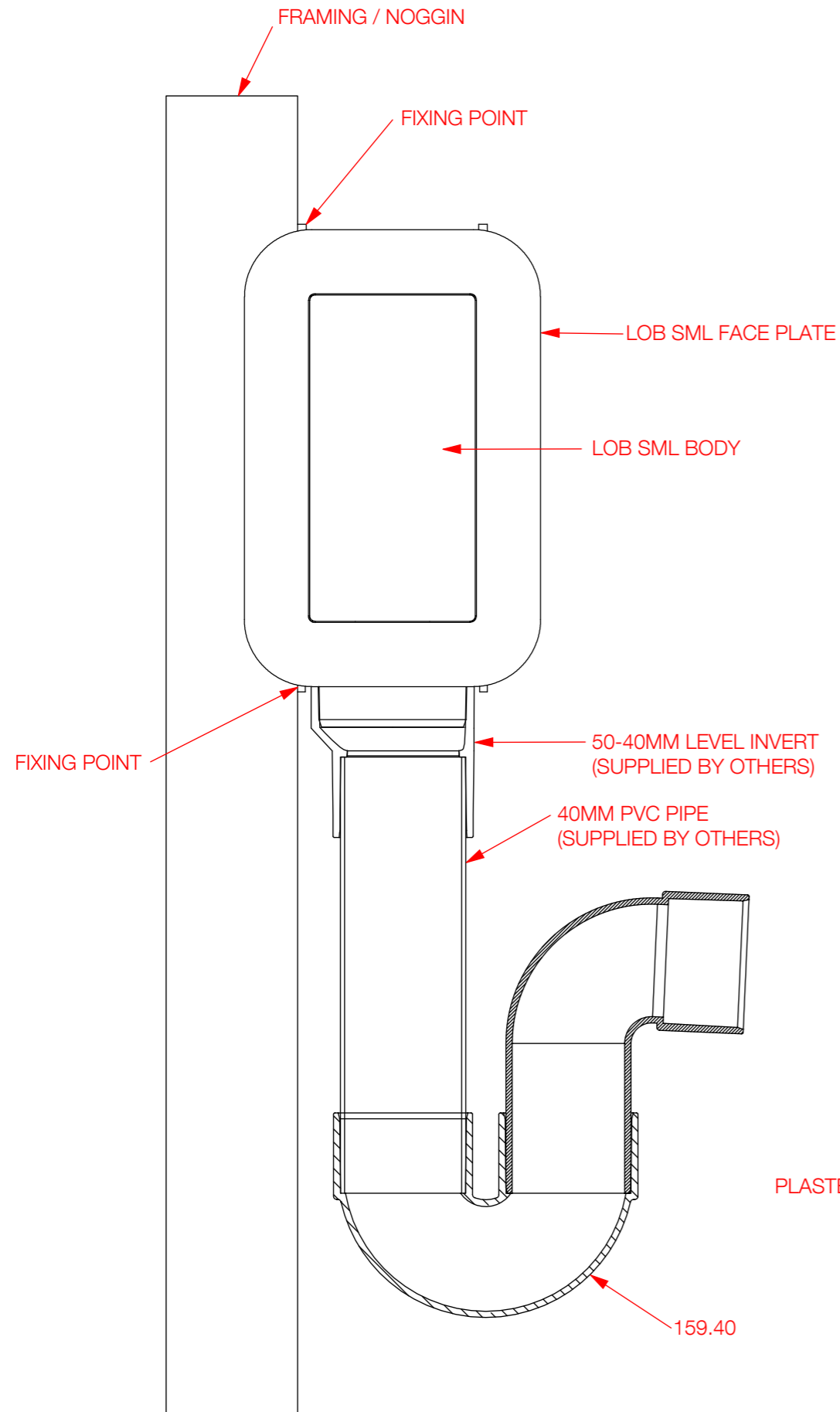

REVISIONS				
REVISION	CHANGE	DESCRIPTION	DRAWN	DATE
1		DESIGN	CP	29.04.2020

DO NOT SCALE DRAWING		TITLE		
REQUESTED	DATE	INSTALLATION : LOB SML IN-WALL WASHING MACHINE TUNDISH		
A.J	22.04.2020			
DRAWN	DATE	APPLICABLE STANDARD(S):		
C.P.	29.04.2020			
APPROVED	DATE	DRAWING REF NUMBER		
		TBC		

TOOL NUMBER	0.0
PART WEIGHT(GRAMS)	0.0
FILE	S/CAD FILES/2014/DRAINAGE/IN/WALL TUNDISH

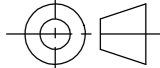
MATERIAL	PVC,ABS	DRAWING REF NUMBER	TBC	
A3	UNITS = MM	SCALE	1 : 2 (UOS)	
				SHEET 2 OF 8

DISCLAIMER : THE DESIGN SUGGESTION IS PROVIDED FOR EVALUATION PURPOSES ONLY.
IT IS NOT TO BE CONSIDERED A FULL DESIGN AS WE ARE NOT THE CONSULTING ENGINEERS. WE ARE MANUFACTURERS. WE ARE NOT PRIVY TO ALL THE INFORMATION PERTAINING TO THIS MATTER AND WE HAVE NO CONTROL OVER THE PROJECT INSTALLATION OF THE PRODUCT. THE DESIGN SUGGESTION IS PROVIDED WITHOUT OBLIGATION. DESIGN IS TO BE CONFIRMED AND APPROVED BY THE ARCHITECT, HYDRAULICS ENGINEER, OR PROJECT MANAGER. ACCURATE MEASUREMENTS SHOULD BE CONFIRMED BY THE PERSON APPROVING THE DESIGN. ALLPROOF ACCEPTS NO LIABILITY FOR THE IMPROPER USE OF THE DESIGN SUGGESTION.