



APPLICATIONS



TOILET



HAND BASIN



BATH



SHOWER



WMTS 106:2019
Certificate No. 23048
Manufacturer: SFA
Brand: Saniflo

PRODUCT REFERENCE:
SA100

Sanibest® Pro

Sanibest® Pro is a heavy duty Macerator suitable for busy commercial environments. Possible connection to a toilet, basin, bath and shower.



TECHNICAL CHARACTERISTICS

Discharge Pipework	20 mm
Motor Power	1100 Watts
Voltages	220-240 V/50 Hz
Working Waste Water Temp	35°C
Product Weight	12 kg
Overall Measurements	507 x 267.5 x 154 mm
Inlet Pipework	40 mm
IP Rating	IP44



Cover allows easy access to electronic components



Robust blade suitable for heavy usage

WHY CHOOSE THIS PRODUCT?

Ideal for heavy usage applications

Robust stainless steel macerator blade for intensive use

Factory pre-mounted non return valve (supplied)

Macerator needs minimum 4.5 L of unrestricted flush for optimal function

Can be equipped with Sanialarm (sold separately)

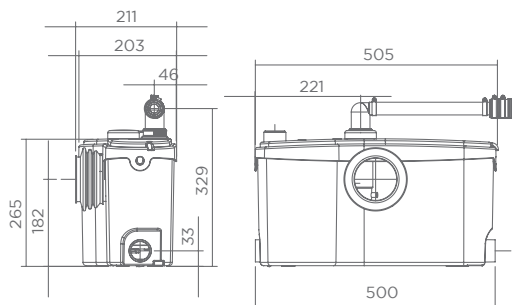

VERTICAL/HORIZONTAL PERFORMANCE

Increase size of horizontal run by one pipe size after 5m. All horizontal pipework requires a minimum of 1:100 fall.

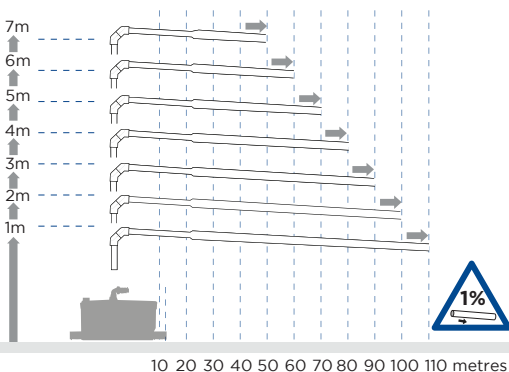

FLOW RATE PERFORMANCE CHART

Discharge height (m)

