

Mirror Unit

vcbc

DESCRIPTION

Mirror Unit 600 – 2 Doors, 2 Glass Shelves, White / Melamine

PRODUCT CODE

M601 / M601M



FEATURES

- Dimensions - W 587 x H 750 x D 120mm
- Available in White or Melamine* finishes.
- White Paint - The paint used on our products is polyurethane or UV based. It is five times harder and more durable than lacquer finishes.
- Melamine - Stunning timber effect finishes. Our wood grain melamine is a low-pressure laminate, made to be durable and low-maintenance.
- Reversible doors.
- NZ-made cabinetry.
- Lighting options are also available with an additional cost.

PAINT / MELAMINE FINISHES*



White Paint

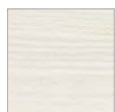

Nordic Ash

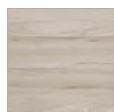

Driftwood

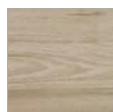

French Oak



Manhattan
Elm



Southern
Oak



Charred
Oak

NOTES

Please see reverse for technical drawings.

*Non-stock item.

MICHEL CÉSAR
VCBC
BURLINGTON
LAUNDRY

/ WHERE BATHROOMS
& LAUNDRIES
COME TOGETHER
BEAUTIFULLY /

info@smail.co.nz
bathco.co.nz

4-8 Ace Place
Kingsland
Auckland 1021
New Zealand

P +64 9 309 9109
F +64 9 309 9343

86 Wigram Road
P.O. Box 8644
Christchurch 8025
New Zealand

P +64 3 343 0969
F +64 3 343 0967

BATH/
CO/

Mirror Unit

vcbc

DESCRIPTION

Mirror Unit 600 – 2 Doors, 2 Glass Shelves, White / Melamine

PRODUCT CODE

M601 / M601M

TECHNICAL DRAWINGS

Top

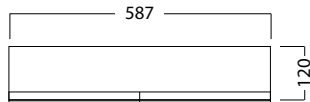

Back

Front

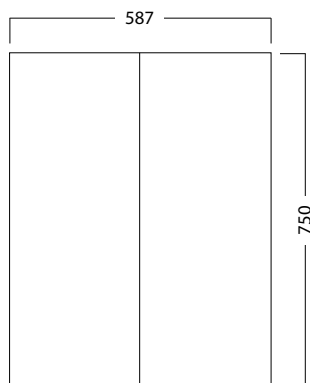

Side Section



Front Section

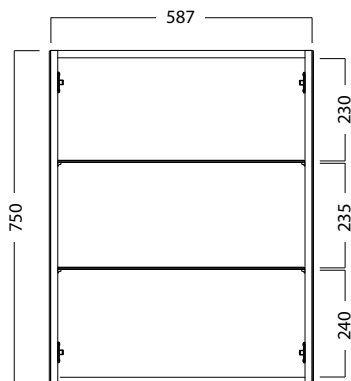

NOTES

Drawing indicates the technical measurement only and is not a reflection of how the unit will look. Sizes are nominal only. All drawings in millimeters. Drawings not to scale.