

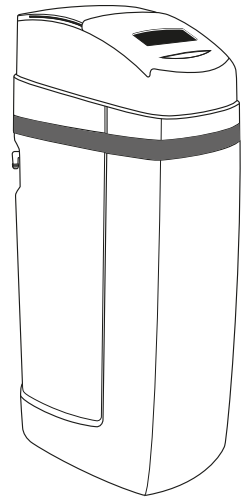

Puretec[®]
PERFECTING WATER



User Guide

SOL-E3 Series

Volumetric Water Softening Appliance



WaterMark
ATS5200.103
Licence No. WM 74593
Australian Certification
Services

What's Inside

Puretec Customer Service	3
Installation Record	4
Before Installation.....	5
Specifications.....	7
Exploded Diagram.....	8
Diagram Identification	9
Installation Procedure.....	10
Programming.....	14
Start-Up.....	16
Regeneration.....	16
Replenishment of Salt Supply.....	17
Type of Salt to Use.....	17
Brine Tank Clean-Out (Yearly).....	17
Media Replacement.....	17
Bypass Valve Operation - optional accessory	18
Troubleshooting Guide	19
Warranty.....	23

Puretec Customer Service

Thank you for purchasing a Puretec Softrol Volumetric Water Softening System. Your system is a proven performer manufactured from only quality materials and components. It will give years of reliability and trouble free operation if maintained properly.

This user guide is designed for Puretec SOL-E3 Water Treatment Systems. Be careful to ensure the information and illustration is applicable to your particular unit.

Caution: Do not use with water that is microbiologically unsafe or without adequate disinfection before or after the system.

The systems are designed for metropolitan supply water but can be used in other situations. For other types of water supply, please contact your local Puretec dealer.

Puretec Water Softeners are designed to run economically for many years, dependent on the initial installation and periodic maintenance.

Flush system for 5 minutes or more, after any period of non-use, more than 2 weeks.

Note: For point of entry installations an approved dual check backflow prevention device must be installed.

When line pressure exceeds 500 kPa, a pressure limiting valve is recommended. Pressures above 875 kPa must have PLV must have a pressure limiting valve installed.

Note: Water softener salt not supplied.

Installation Record

For future reference, fill in the following data

Product Information	
Model Number:	
Serial / Batch Number:	
Purchased from:	
Date of Installation:	
Installer / Plumber Details:	

Water Analysis Information	
Hardness:	_____ ppm / mg/L
Iron:	_____ ppm / mg/L
Manganese:	_____ ppm / mg/L
pH:	_____
TDS (Total Dissolved Salts):	_____ ppm / mg/L
Conductivity:	_____ EC / uS/cm
Chloride:	_____ ppm / mg/L
Sodium:	_____ ppm / mg/L

Before Installation

Professional Installation Required

- Installation requires shutting water off to home, cutting home water supply pipe and using a welding torch to add piping and fittings. Specialised tools and skills are required, this must be completed by a qualified tradesperson.

Make Sure Your Water Has Been Thoroughly Tested

- An analysis of your water should be made prior to the selection of your water conditioning equipment. Your dealer will generally perform this service for you, and may send a sample to the factory for analysis and recommendations. Enter your analysis information on page 4 for your permanent record.
- Softeners are designed to reduce hardness but can handle reasonable amounts of soluble iron if consideration is given to content when selecting model and regeneration settings. For best results contact Puretec to discuss.

Install Water Conditioning Equipment Correctly

Select the location of your water softener with care. Various conditions which contribute to proper location are as follows:

- Install as close as possible to a drain.
- Install in correct relationship to other water treatment equipment. Contact Puretec for assistance.
- Install the softener in the supply line BEFORE the water heater. Temperatures above 43.3°C (110°F) will damage the softener and void the warranty.
- DO NOT install the softener in a location where freezing temperatures occur. Freezing may cause permanent damage and will also void the warranty.
- DO NOT install where water hammer conditions may occur without installing an arrestor.
- Allow sufficient space around the installation for easy servicing. Provide a non-switched 240V power source for the control valve.

Things to Remember While Planning Your Installation:

- All installation procedures **MUST** conform to local plumbing codes.
- If lawn sprinklers, a swimming pool, or geothermal heating/cooling or water for other devices/activities are to be treated by the water softener, a larger model **MUST** be selected to accommodate the higher flow rate plus the backwashing requirements of the water softener. Contact Puretec for assistance.



WARNINGS

- The control valve, fittings and/or bypass are designed to accommodate minor plumbing misalignment but are not designed to support the weight of a system or the plumbing.
- Do not use petroleum jelly, oils, other hydrocarbon lubricants or spray silicone anywhere. A silicon lubricant may be used on the black o-rings but it is not necessary.
- Do not use pipe dope or other sealants on threads. Thread seal tape is the preferred sealant but is not necessary on the nut connection or caps because of o-ring seals.
- All plumbing should be done in accordance with local plumbing codes. The pipe size for the drain line should be a minimum of 5/8".
- Avoid getting primer and solvent cement on filter system.
- Install grounding strap on metal pipes if required.
- Ensure the system is protected against high pressure and extreme temperatures.

Specifications

Operating Pressure Min/Max:	140-875 kPa
Operating Temperature Min/Max:	0-48 °C (protect from freezing)
Electrical Connection:	240V / 50 Hz
Inlet/Outlet Connection:	25 mm
Drain Connection:	5/8"
Overflow Connection:	5/8"

Width (mm) (W):	285
Height (mm) (H):	1125
Depth (mm) (D):	490
Dry Weight (kg):	SOL30-E3 - 29 kg.
	SOL40-E3 - 37 kg.
Maximum salt storage capacity:	150 kg

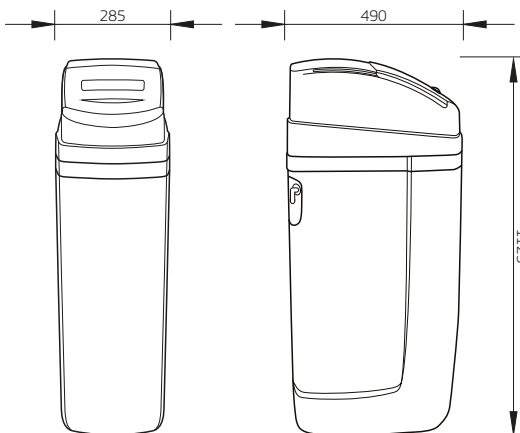

Exploded Diagram

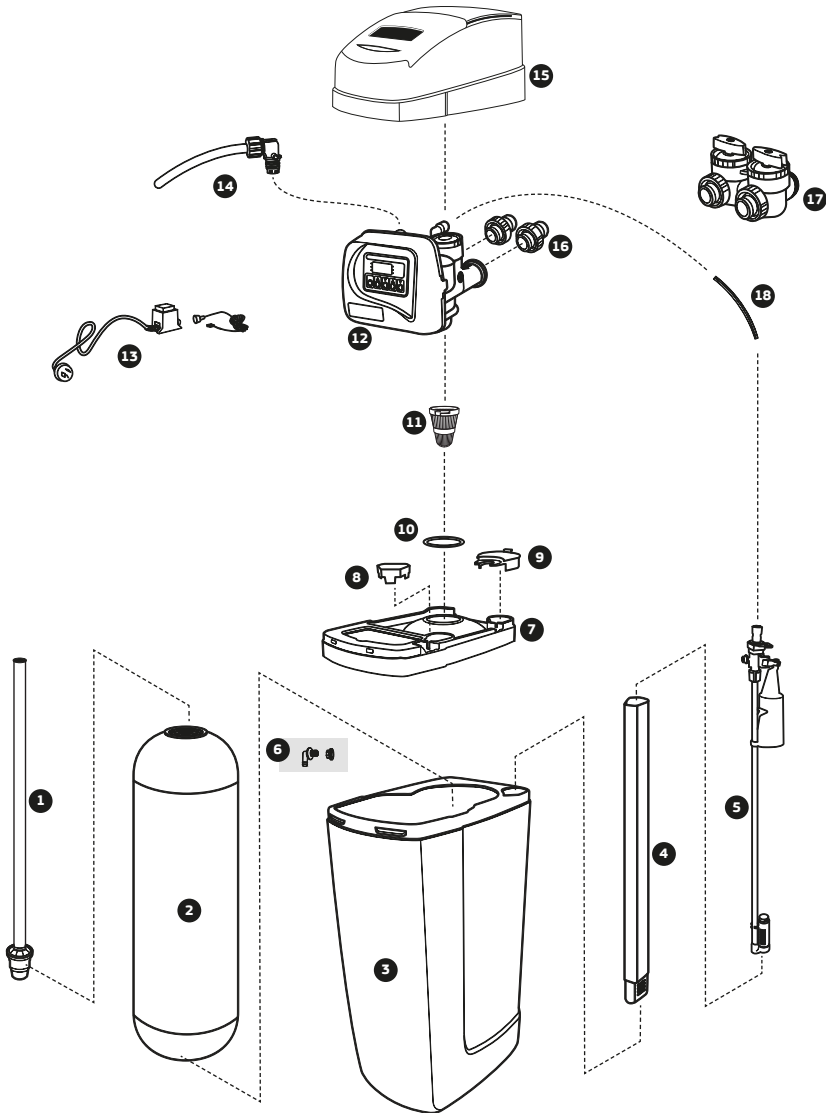

Parts Identification

Item	Part no	Description
1	WTD2030	Riser Pipe
2	-	Pressure Tank
3	WTB1035	Cabinet Domestic Softener
4	-	Brine Well
5		Brine Pick-Up Assembly
6	WTB1035	2pc Overflow Kit
7	-	Brine Tank Lid
8	-	Brine Well Blank
9	-	Brine Well Lid
10	WTV3030	Pressure Tank Collar UV Shield

Item	Part no	Description
11	WTD1010	Top Screen
12	WTV4200	Volumetric Valve
13	WTV5135	Transformer Suits Auto Valves
14	-	Drain Tube Assembly
15	WTB2100	Softener Cover
16	WTV5060	Plastic Fitting Kit
17	WTV5000	Bypass Assembly (purchased separately)
18	KTU6BK	Tubing High Pressure 3/8" Black

Diagram Identification

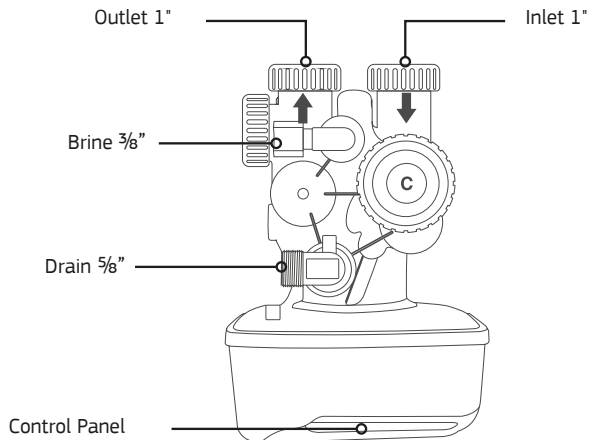

Installation Procedure

1 Unpack the Equipment

Ensure all parts are present and have not been damaged in transport.
 You should have:

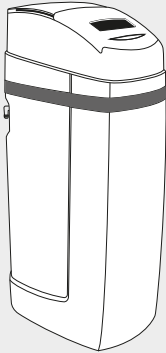

Water Softener



Bypass Assembly
 (purchased separately)



Drain Tube Assembly



User Guide

2 Extra Items Required



Bag of Salt (refer to page 17 for the type of salt to be used).



5/8" Tubing high pressure for drain and overflow (refer to page 13).

3 Ensure Water Has Been Tested

Input values into Table on page 4 and the analysis has been inspected by Puretec.

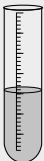

Water Analysis Information	
Hardness	... 150 ... ppm / mg/L
Iron	... 0.3 ... ppm / mg/L
Manganese	... 0.1 ... ppm / mg/L
pH	7
TDS (Total Dissolved Salts)	... 275 ... ppm / mg/L
Conductivity	... 404 ... EC / uS/cm
Chloride	... 5.5 ... ppm / mg/L
Sodium	... 9.6 ... ppm / mg/L



Customer Service Helpline
 1300 140 140 (AU) 0800 130 140 (NZ)



4 Position the Softener on a level surface.

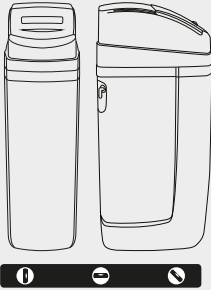

Environmental conditions

Operating temperature: 0-48°C

Water conditions

Temperature: 0-50°C

Pressure: 140-875 kPa

5 Installing the Bypass (purchased separately)

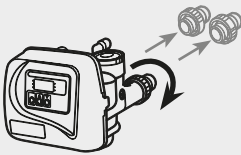

Uninstall the plastic fittings by turning the knob counter clockwise.

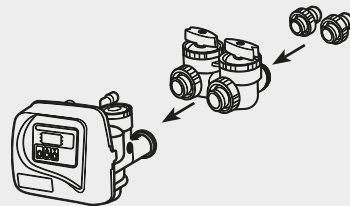

Connect the bypass assembly followed by the plastic fittings. Hand tighten the knobs, do not overtighten.

Refer to page 18 for bypass operation.

6 Connecting the Softener

Connect the softener to main plumbing. Do not solder brass adapters while they are inserted in the control module.

Apply plumbing tape to the nipple as required. Connect the pipe work to the valve, refer to page 9 for identification.

FOLLOW LOCAL
PLUMBING CODES

Note: Solder joints must be done prior to connecting to the valve fittings. Leave at least 6" between the fitting and solder joints when soldering pipes. Failure to do this could cause heat damage to the fittings.

This should be carried out by a qualified tradesman.

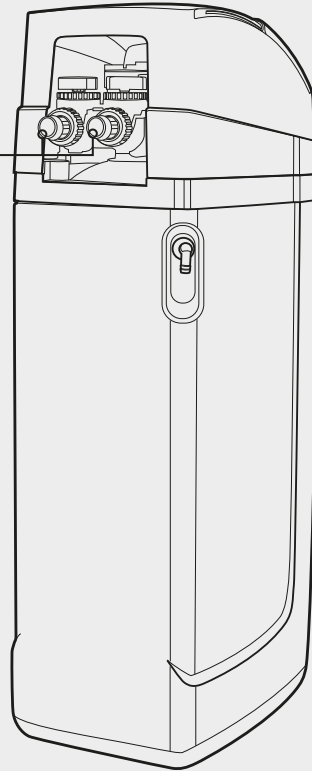

7 Connecting the Drain Line

Locate the 300 mm drain tube and attach to the drain connection, refer to page 9 for identification of the drain port.

Connect extra tube (tubing not supplied) onto the 5/8" drain line from the valve to the drain. Ensure the drain line is not kinked. The line must not travel more than 2.4 m up from the valve, otherwise increase the diameter of the drain line.

Connect drain and overflow to sewer or storm water, whatever is approved by local authority for salty discharge water.

Ensure drain line has an adequate air gap of 2 times the pipe diameter or 25 mm, whichever is larger.

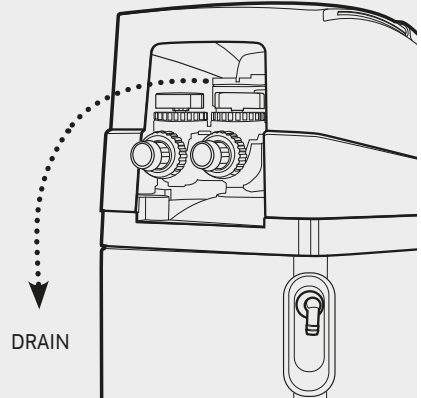

8 Connecting the Overflow

Connect tubing onto the 5/8" overflow fitting (tubing not supplied) and run the line to the drain. **Do not connect the overflow into the drain line**, as it must be a direct and separate line to the drain. Allow an air gap as per the drain line. Make sure the drain is not higher than the overflow.

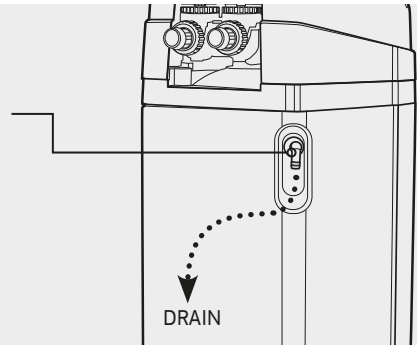

9 Programming

6.1 Plug into an uninterrupted electrical outlet.

Note: the system transformers are not weather resistant and should be adequately protected. All electrical connections must be connected accordingly to local codes.

6.2 Proceed to 'Programming' section.

Programming - E3

GENERAL OPERATION

When the system is operating one of two displays will be shown. Pressing NEXT will alternate between the displays. One of the displays is always the current time of day. The second display is one of the following: days remaining or gallons remaining. Days remaining is the number of days left before the system goes through a regeneration cycle. Capacity remaining is the number of gallons that will be treated before the system goes through a regeneration cycle. The user can scroll between the displays as desired.

If the system has called for a regeneration that will occur at the present time of regeneration, the words REGEN TODAY will appear on the display.

When water is being treated (i.e. water is flowing through the system) the word 'Softening' or 'Filtering' flashed on the display if a water meter is installed.

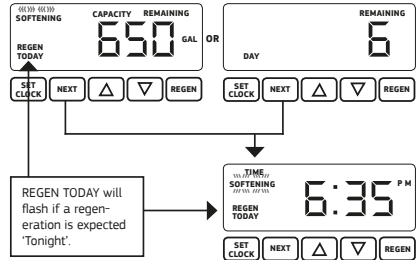

SET TIME OF DAY

The user can also set the time of day. Time of day should only need to be set after expended power outages or when daylight savings begins or ends. If an extended power outage occurs, the time of day will flash on and off which indicates the time of day should be reset.

Step 1: Press SET CLOCK

Step 2: Current Time (hour): Set the hour of the day using ▲ or ▼ buttons.

Press NEXT to go to step 3.

Step 3: Current Time (minutes) : Set the minutes of the day using ▲ or ▼ buttons. Press NEXT to exit Set Clock.

Press REGEN to return to the previous step.

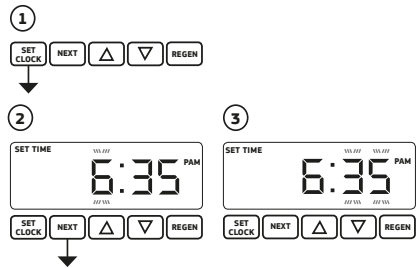

OTHER SETTINGS

Step 1: Press NEXT and ▲ simultaneously for 5 seconds.

Step 2: Hardness : Set the amount of hardness in grains of hardness as calcium carbonate per gallon using the ▲ or ▼ buttons. The default is 13 with value ranges from 1 to 150 in 1 grain increments. The conversion factor to mg/l or ppm is 17 (divide mg/l or ppm by 17 = grains/gallon).

Step 3: Day Override: When gallon capacity is set to off, sets the number of days between regeneration. When gallon capacity is set to AUTO or to a number, sets the maximum number of days between regeneration. If value set to 'OFF' regeneration initiation is based solely on gallons used. If value is set as a number (allowable range from 1 to 28) a regeneration initiation will be called for on that day even if sufficient number of gallons were not used to call for a regeneration. Set Day Override using ▲ or ▼ buttons:

- Number of days between regeneration (1 to 28); or
- 'OFF'

Press NEXT to go to step 4. Press REGEN to return to previous step.

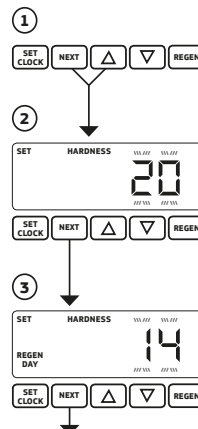

continued on the next page

Programming - E3

Step 4: Next Regeneration Time (hour): Set the hour of the day for regeneration using Δ or ∇ buttons. AM/PM toggles after 12. The default time is 2:00 am. Press NEXT to go to step 5. Press Regen to return to previous step.

Step 5: Next Regeneration Time (minutes): Set the minutes of day for regeneration using Δ or ∇ buttons. The default setting is '00'. Press NEXT to exit Installer Displays/Settings.

Press REGEN to return to previous step.

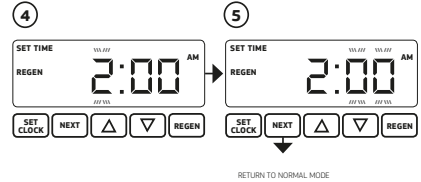

REGENERATION MODE

Typically a system is set to regenerate at a time of low water usage. An example of a time with low water usage is when a household is asleep. If there is a demand for water when the system is regenerating, untreated water will be used.

When the system begins to Regenerate, the display will change to include information about the step of the regeneration process and the time remaining for that step to be completed.

The system runs through the steps automatically and will reset itself to provide treated water when the regeneration has been completed.



MANUAL REGENERATION

Sometimes there is a need to regenerate the system sooner than when the system calls for it, usually referred to as a manual regeneration. There may be a period of heavy water usage because of guests or a heavy laundry day.

To initiate a manual regeneration at the preset delayed regeneration time, when the regeneration time option is set to 'NORMAL' or 'NORMAL + on 0', press and release 'REGEN'. The words 'REGEN TODAY' will flash on the display to indicate that the system will regenerate at the present delayed regeneration time. If you pressed the 'REGEN' button in error, pressing the button again will cancel the request.

Note: If the regeneration time option is set to 'on 0' there is no set delayed regeneration time so 'REGEN TODAY' will not activate if 'REGEN' button is pressed.

To initiate a manual regeneration immediately, press and hold the 'REGEN' button for three seconds. The system will begin to regenerate immediately. The request cannot be cancelled.

Note: For softeners, if brine tank does not contain salt, fill with salt and wait at least two hours before regenerating.

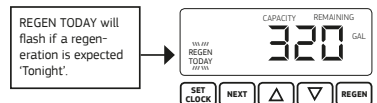

POWER LOSS

If the power goes out for less than two hours, the system will automatically reset itself. If an extended power outage occurs, then time of day will flash on and off which indicates that time of day should be reset. The system will remember the rest.

Start-up

Now programming is completed you are ready to start the system.

1. Fill the brine tank with 'water softener' salt to approximately half full (salt not included). This will require approximately 60 kg (this is only required initially).
2. Add approximately 15 litres of water to the salt in the brine tank. This is only required for the initial setup.

Note: The water level will drop significantly after the first backwash, and may disappear below the salt line. This is normal and no extra water will be required.

3. Open the nearest tap downstream of the filter system (after the filter system).
4. Allow water to flow through the system slowly, and allow all air to escape out of the closest tap. Wait until the water is flowing out of the tap and then increase the flow slowly up to full flow. Allow to run for 5 - 10 minutes.
5. Close the opened tap and check for leaks.
6. Conduct a full manual regeneration.
7. Your system is ready for use.

Regeneration

MODEL	CAPACITY OF SYSTEM (L) WITH DIFFERENT HARDNESS LEVELS				
	100 mg/L	200 mg/L	300 mg/L	400 mg/L	500 mg/L
SOL30-E3	10150	5075	3380	2537	2030
SOL40-E3	15400	7700	5130	3850	3080

E3 Valve (Regeneration Time: 90 mins)

This will adjust regeneration automatically once you have entered the correct hardness level in the programming section.

Replenishment of Salt Supply

The salt storage capacity of the brine tank is approximately 100 kg. During each regeneration a small amount of salt is consumed, thus requiring periodic replenishment for a continuous supply of softened water (the frequency and salt dosage level is dependent on the regeneration schedule).

We recommend to maintain the salt level in the brine tank to 1/2 to 2/3 full. The water level in the brine tank is maintained automatically and does not require manual intervention. **NOTE:** The water level is usually below the salt level & therefore cannot be seen (this is not a problem).

Always replenish salt before the supply is exhausted.

Note: No extra water is required when topping up the salt level.

Type of Salt to Use

Any type of water softener salt may be used, but for best results, we recommend using coarse solar salt called "water softener salt" or alternatively "pool salt".

Brine Tank Clean-Out (Yearly)

To help prevent service problems the brine tank should be emptied and flushed out with a garden hose, when dirt and other insolubles accumulate on a regular basis. Shut off water inlet supply and depressurise the system before service.

Steps to follow:

1. Disconnect brine line at either end.
2. Turn brine tank upside down and discard old salt.
3. Rinse out with a garden hose.
4. Reconnect brine line.
5. Before loading salt, using a pail or garden hose, add approximately 15 Litres of water to the brine tank.

Media Replacement

Resin ordering code: **RMK-SOL30** for SOL30-E3 and **RMK-SOL40** for SOL40-E3.

Customer Service Helpline at **1300 140 140** (AU) and **0800 130 140** (NZ) for more details.

The nuts and caps are designed to be unscrewed or tightened by hand or with the special plastic wrench. If necessary a pliers can be used to unscrew the nut or cap. Do not use a pipe wrench to tighten or loosen nuts or caps. Do not place screwdriver in slots on caps and/or tap with a hammer.

Bypass Valve Operation - optional accessory

Normal Operation

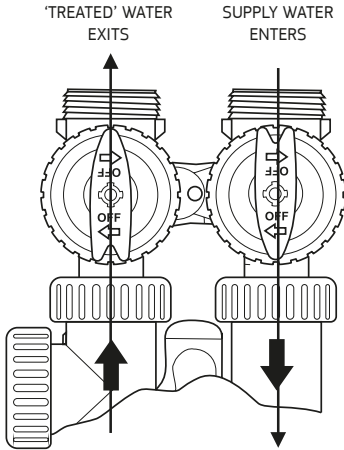

Bypass Operation

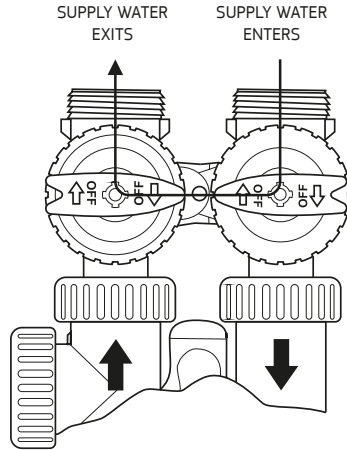

Diagnostic Mode

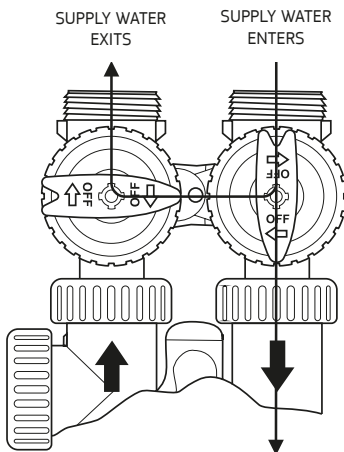

Shut Off Mode

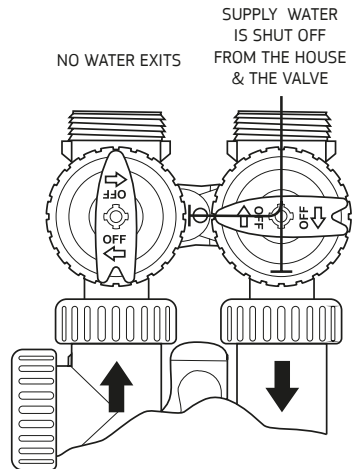

Troubleshooting Guide

<p>'Dry' Reset Procedure</p> <p>From time to time, the valve may display an error code for various reasons. The first troubleshooting step is to perform a 'dry' reset.</p>	<p>Remove the faceplate, opening the tabs on either side of the valve. This will expose the Power Circuit board with a number of wires connected.</p> <p>On the bottom right hand corner is a 4 pin adaptor labelled '12VAC PWR', disconnect the adaptor and reconnect after 5 seconds. The valve will then whirl twice, and should return to the normal screen.</p> <p>If the error message is still present, refer to the troubleshooting guide.</p>
--	--

PROBLEM	POSSIBLE CAUSE	SOLUTION
No display/blank screen on valve.	A. Transformer not connected.	A. Connect transformer.
	B. No power at outlet/source.	B. Use working outlet/repair outlet.
	C. Switched outlet/improper voltage.	C. Use uninterrupted outlet/ensure source is delivering proper voltage.
	D. Dead battery.	D. Replace battery (CR2032).
	E. Defective transformer.	E. Replace transformer.
	F. Defective PC Board.	F. Replace PC Board.
Valve does not display correct time of day.	A. Power outage(s).	A. Reset time of day, replace battery (CR2032).
	B. Time of day set incorrectly.	B. Reset to correct time of day.
	C. Switched outlet.	C. Use uninterrupted outlet.
	D. Tripped breaker switch.	D. Reset breaker switch.
	E. Defective PC Board.	E. Replace PC Board.
Valve regenerates at wrong time of day.	A. Power outage(s).	A. Reset time of day, replace battery (CR2032).
	B. Time of day set incorrectly.	B. Reset to correct time of day.
	C. Time of regeneration set incorrectly.	C. Reset regeneration time.
	D. Control valve set for immediate regeneration.	D. Contact Puretec for assistance.
	E. Control valve set for delayed and/or immediate regeneration.	E. Contact Puretec for assistance.
Time of day flashes on and off.	A. Power outage(s).	A. Reset time of day, replace battery (CR2032) and then perform a 'dry' reset.

Troubleshooting Guide

PROBLEM	POSSIBLE CAUSE	SOLUTION
Valve does not regenerate when performing a manual regeneration.	A. No power to valve.	A. Refer to 'No display/blank screen on valve'.
	B. Broken drive gear or drive cap assembly.	B. Replace drive gear or drive cap assembly.
	C. Broken piston rod.	C. Replace piston rod.
Valve does not regenerate automatically, but does when performing a manual regeneration.	A. Bypass valve in bypass position/faulty.	A. Turn bypass to normal operation/replace bypass.
	B. Meter loosely/not connected to PC Board.	B. Connect meter into the three pin connector labelled METER on PC Board.
	C. Restricted/stalled meter turbine.	C. Remove meter and check for rotation or foreign material.
	D. Incorrect programming.	D. Contact Puretec for assistance.
	E. Defective meter.	E. Replace meter.
	F. Defective PC Board.	F. Replace PC Board.
Hard/Untreated water delivered to service.	A. Bypass valve is in bypass operation/faulty.	A. Turn bypass to normal operation/replace bypass.
	B. Media is exhausted due to high water usage.	B. Check program settings or diagnostics for abnormal water usage.
	C. Fouled media bed.	C. Clean/replace media.
	D. Meter not registering/faulty.	D. Remove meter and check for rotation or foreign material/replace meter.
	E. Water quality fluctuation.	E. Test water and contact Puretec for assistance.
	F. No regenerant or low level of regenerant.	F. Refill regenerant tank.
	G. Valve fails to draw regenerant.	G. Refer to 'Valve fails to draw in regenerant'.
	H. Insufficient regenerant level in regenerant tank.	H. Contact Puretec for assistance.
	I. Leak from seal/spacer stack assembly.	I. Clean/replace spacer stack assembly.
Control valve uses too much regenerant.	A. Incorrect refill setting.	A. Contact Puretec for assistance.
	B. Incorrect program setting.	B. Contact Puretec for assistance.
	C. Valve regenerating frequently.	C. Check for leaking fixtures or system undersized.

Troubleshooting Guide

PROBLEM	POSSIBLE CAUSE	SOLUTION
Regenerant being delivered to service	A. Low water pressure	A. Check incoming water pressure – water pressure must remain at minimum of 25 psi
	B. Incorrect injector size	B. Replace injector with correct size for application
	C. Restricted/kinked drain line	C. Check drain line for restrictions or debris, or unkink drain line
Excessive water in regenerant tank.	A. Incorrect program settings.	A. Contact Puretec for assistance.
	B. Plugged injector.	B. Clean/replace injector.
	C. Loose/damaged drive cap assembly.	C. Tighten/replace drive cap assembly.
	D. Leak from seal/spacer stack assembly.	D. Clean/replace spacer stack assembly.
	E. Restricted/kinked drain line.	E. Check drain line for restrictions or debris, or unkink drain line.
	F. Plugged backwash flow controller.	F. Clean/replace backwash flow controller.
	G. Plugged refill flow controller.	G. Clean/replace refill flow controller.
Valve fails to draw in regenerant.	A. Plugged injector.	A. Clean/replace injector.
	B. Regenerant piston failure.	B. Clean/replace regenerant piston.
	C. Leak in regenerant line.	C. Inspect regenerant line for air leak.
	D. Restricted/kinked drain line.	D. Check drain line for restrictions or debris, or unkink drain line.
	E. Drain line too long or too high.	E. Shorten length and/or height.
	F. Low water pressure.	F. Check incoming water pressure – water pressure must remain at minimum of 25 psi.
Water running to drain.	A. Power outage during regeneration.	A. Upon power being restored control will finish the remaining regeneration time. Reset time of day, replace battery (CR2032).
	B. Foreign material present in valve.	B. Remove drive cap, piston and spacer assemblies. Clean and relubricate components, assemble the valve and run a manual backwash.
	C. Leak from seal/spacer stack assembly.	C. Clean/replace spacer stack assembly.
	D. Piston assembly failure.	D. Clean/replace piston assembly.
	E. Loose/damaged drive cap assembly.	E. Tighten/replace drive cap assembly.

PROBLEM	POSSIBLE CAUSE	SOLUTION
Error Code - E1 Control unable to sense motor movement.	A. Motor not inserted fully into engage position, motor wires broken or disconnected.	A. Disconnect power, make sure the motor is fully engaged, check for broken wires, make sure two pin connector is connected to the two pin connection on the PC Board labelled MOTOR. Connect power and perform a 'dry' reset.
	B. PC Board not correctly installed.	B. Ensure PC Board is correctly clipped into drive bracket and perform a 'dry' reset.
	C. Board unable to read middle reduction gear.	C. Check foil on reduction gear; clean any foreign material on the foil.
	D. Missing/damaged reduction gears.	D. Replace missing gears.
	E. Defective PC Board.	E. Replace PC Board.
Error Code - E2 Control valve motor ran too short and was unable to find the next cycle position and stalled.	A. Foreign material lodged in valve.	A. Clean/replace piston/spacer stack assembly. Perform a 'dry' reset.
	B. Mechanical binding.	B. Check piston, spacer stack assembly, drive bracket and main drive gear interface. Perform a 'dry' reset.
	C. Main drive gear too tight.	C. Loosen main drive gear. Perform a 'dry' reset.
	D. Incorrect voltage being delivered to valve.	D. Check voltage of power source. Perform a 'dry' reset.
	E. Incorrect programming.	E. Contact Puretec for assistance.
Error Code - E3 Control valve motor ran too long and was unable to find the next cycle position.	A. Motor failure during regeneration.	A. Check motor connections. Perform a 'dry' reset.
	B. Foreign material lodged in valve.	B. Clean/replace piston/spacer stack assembly. Perform a 'dry' reset.
	C. Drive bracket not correctly installed.	C. Snap drive bracket in correctly. Perform a 'dry' reset.
Error Code - E4 Control valve motor ran too long and timed out trying to reach home position.	A. Drive bracket not correctly installed.	A. Snap drive bracket in correctly. Perform a 'dry' reset.
Valve does not indicate that water is flowing.	A. Bypass valve is in bypass operation/faulty.	A. Turn bypass to normal operation/replace bypass.
	B. Meter not connected.	B. Connect meter to three pin connection labelled MOTOR on PC Board.
	C. Restricted/stalled meter turbine.	C. Remove meter and check for rotation or foreign material/replace meter.
	D. Defective meter.	D. Replace meter.
	E. Defective PC Board.	E. Replace PC Board.

Warranty

Any claim under this warranty must be made within 6 years of the date of purchase of the product. This product is warranted to be free of defect of material and workmanship for 6 years from date of purchase. 6 year warranty is 1 year parts and labour, plus 5 years parts only. Excludes consumables. To make a claim under the warranty, take the product and proof of purchase to place where you purchased the product, and they will lodge a Warranty Request with Puretec.

Puretec will pay your reasonable, direct expenses of claiming under this warranty. You may submit details and proof of your expense claim to place of purchase for consideration.

The warranty only applies if the product was used and/or installed in accordance with the user guide and/or installation instructions. This warranty is given in lieu of all other express or implied warranties and manufacturer shall in no circumstance be held liable for damages consequential or otherwise or delays caused or faulty manufacturing except as excluded by law.

Applicable to all above, is that the warranties need to be approved by Puretec to ensure product was not incorrectly used, installed or claimed. False and incorrect claims will be pursued at Puretec's discretion, including chargeable inspection and labour costs incurred.

Warranty/Australia

This warranty is given by Puretec Pty Ltd, ABN 44 164 806 688, 37-43 Brodie Road, Lonsdale SA 5160, telephone no. 1300 140 140 and email at sales@puretec.com.au.

This warranty is provided in addition to other rights and remedies you have under law: Our goods come with guarantees which cannot be excluded under the Australian Consumer Law. You are entitled to replacement or refund for a major failure and to compensation for other reasonably foreseeable loss or damage. You are also entitled to have the goods repaired or replaced if the goods fail to be of acceptable quality and the failure does not amount to a major failure.

Warranty/New Zealand

This warranty is given by Puretec Ltd, Reg. No 4464398, Level 2, Onehunga Mall, Auckland 1061, telephone no. 0800 130 140 and email at sales@puretec.co.nz.

This warranty is provided in addition to other rights and remedies you have under law: Our goods come with guarantees which cannot be excluded under the Consumer Guarantees Act. You are entitled to replacement or refund for a major failure and to compensation for other reasonably foreseeable loss or damage. You are also entitled to have the goods repaired or replaced if the goods fail to be of acceptable quality and the failure does not amount to a major failure.



Puretec[®]
PERFECTING WATER

AUSTRALIA

P 1300 140 140

E sales@puretec.com.au

W puretec.com.au

NEW ZEALAND

P 0800 130 140

E sales@puretec.co.nz

W puretec.co.nz