

Schweigen Repose - Silent Bathroom Fan Specifications

schweigen

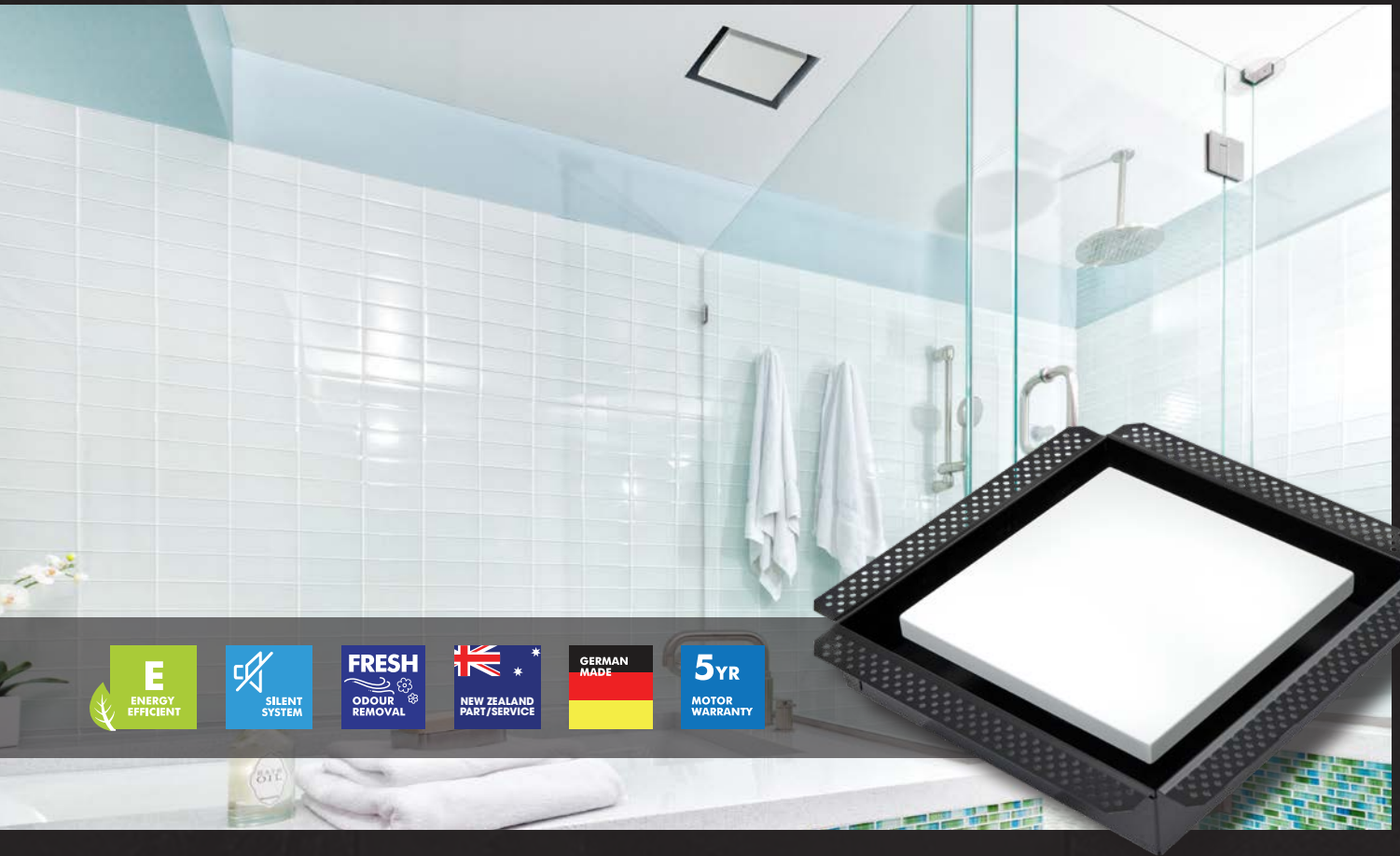

The Schweigen Repose is designed for new builds and is plastered into the ceiling offering a seamless finish. The system comes with a New Zealand-made square metal ceiling vent, and an option of one or two room extraction. All systems come with necessary ducting.

Silent Bathroom Extraction

The German manufactured IsoDrive motor removes steam and odours quickly and quietly. With the motor mounted on the outside of the home, you won't even know it's on.

The Most Powerful Extraction in New Zealand

With up to 900m³/hr (250 l/s) of air extraction, the IsoDrive motors efficiently remove steam and odours while eliminating condensation from mirrors, glass and windows.

Fresh & Hygienic Mould Prevention

Helps in the prevention of mould build-up by hygienically removing steam, odours and airborne bacteria without the use of harmful chemicals, leaving your bathroom clean and fresh.

Comply with Government Regulations

Schweigen extraction systems comply with the ventilation standards of the NZ Ministry of Housing and Urban Development and as well as section 138B of the Residential Tenancies Regulations 2019 (Healthy Homes Standards) stating that for a bathroom:

- (a). the fan and all exhaust ducting must have a diameter of at least 120 mm
- (b). the fan and all exhaust ducting must have an exhaust capacity of at least 25 l/s (90m³/hr)

Energy Efficient

New Zealand's most energy efficient venting system, using only 62 watts of electricity.

Two Room Extraction

Each of our systems in the range can be purchased in a two room configuration, capable of providing extraction for two adjacent rooms with one motor. They also come with an option of two motor sizes.

5+ Year In-Home Warranty

Schweigen offers the peace of mind of a comprehensive 5-year In-Home Warranty on the IsoDrive motor.

Schweigen Repose - Silent Bathroom Fan - Specifications



Repose Single Room

650m³/hr Motor - Product Code: BR500RP

System Includes: 650m³/hr Motor, Repose Grill, Bell Mouth Adaptor, 100mm Pipe, Flexible Ducting (3m), Back Draught Shutter, System and Instruction Manual

Repose Double Room

650m³/hr Motor - Product Code: BR500RPY

System Includes: 650m³/hr Motor, Repose Grill x 2, Bell Mouth Adaptor, 100mm Pipe, Flexible Ducting (3m) x 2, Back Draught Shutter, System, Y-Connector and Instruction Manual

Repose Double Room

900m³/hr Motor - Product Code: BR900RP

System Includes: 900m³/hr Motor, Repose Grill x 2, Bell Mouth Adaptor, 100mm Pipe, Flexible Ducting (3m) x 2, Back Draught Shutter, System, Y-Connector and Instruction Manual

Motor Mounting Options

Appropriate access required for ducting

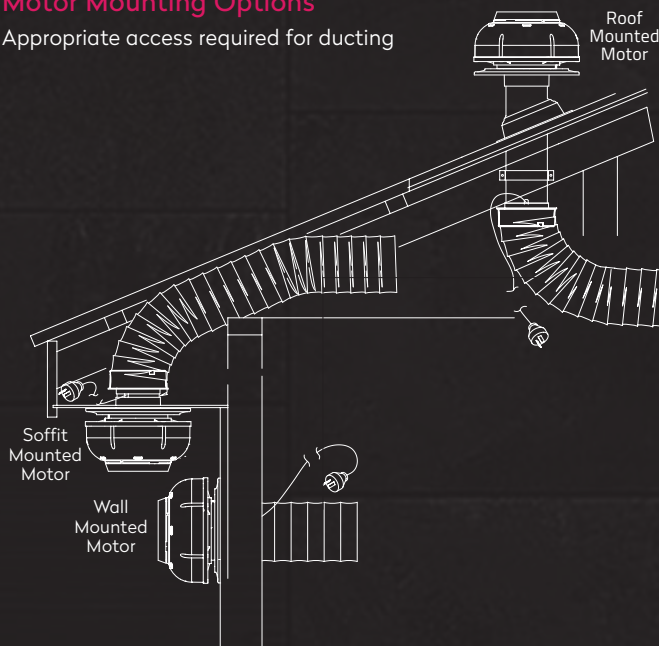

Two-Room Installation

Applies to all 3 Mounting Options

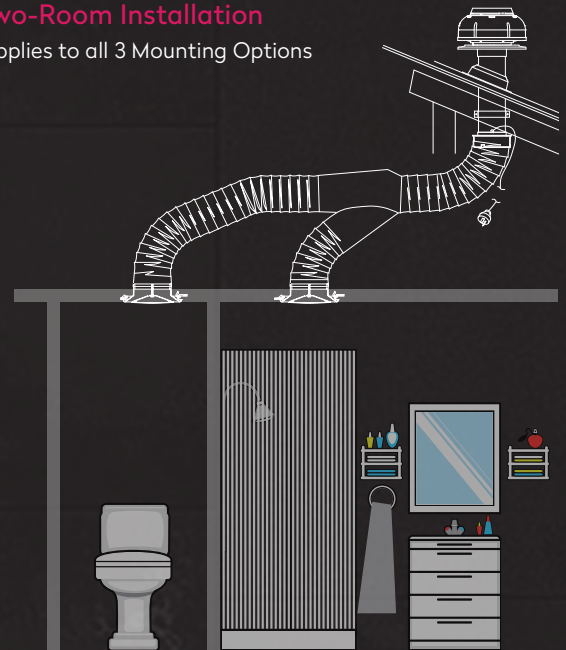

Repose Vent Dimensions

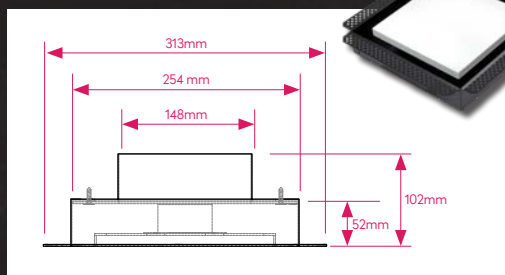

Dimension of Vents: Outer Frame - 315mm x 315mm
Diffuser - 200mm x 200mm

650m³/hr Motor Dimensions

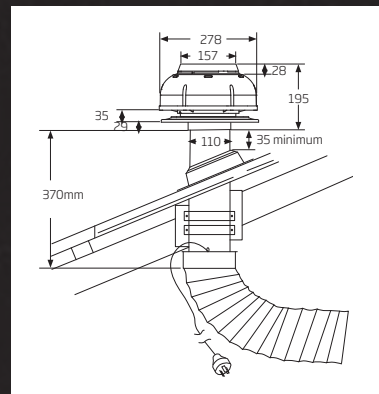

550m³/hr - 650m³/hr (150 l/s-180 l/s)
extraction power

900m³/hr Motor Dimensions

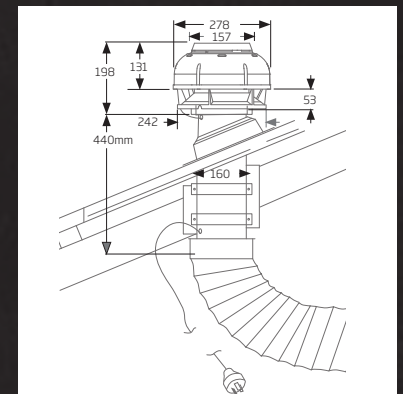

850m³/hr - 900m³/hr (220 l/s-250 l/s)
extraction power

schweigen

For more information contact Parex Industries Limited on
Tel: 0800 200 510 or email: info.parex@emerson.com

schweigen.co.nz