

Description

Sharp 900 Wall-Hung Vanity, 2 Drawers, White / Melamine

Product Code

SH90D2WH / M



Features

- Dimensions - W 900mm x H 590mm x D 475mm
- Paint - The paint used on our products is polyurethane or UV based. It is five times harder and more durable than lacquer finishes. White only.
- Timber effect (Melamine) - Our woodgrain melamine is a low pressure laminate. Colours available are Nordic Ash, Manhattan Elm, Southern Oak, French Oak, Driftwood or Charred Oak.
- Match it with an aluminium rail, black aluminium rail or melamine/white paint finish handle.
- Soft-close drawers.
- Includes a top, cabinet and handle.
- Excludes tapware & accessories.

PAINT / MELAMINE FINISHES*



White Paint



Nordic Ash

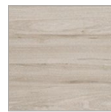

Driftwood



French Oak
Wilderness



Manhattan
Elm



Southern Oak
Wilderness



Charred Oak

Notes

Please see reverse for technical drawings.

Description

Sharp 900 Wall-Hung Vanity, 2 Drawers, White / Melamine

Product Code

SH90D2WH / M

Technical Drawings

Top

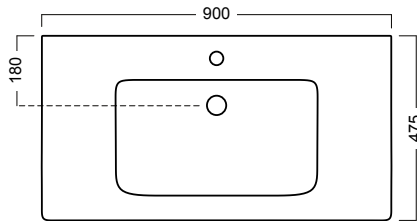

Back

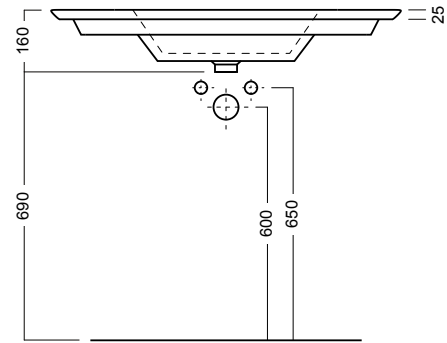

Front

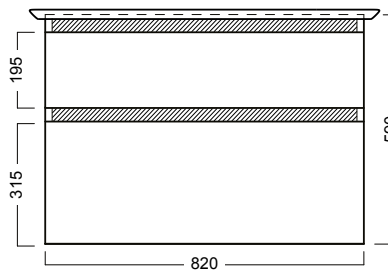

Side Section

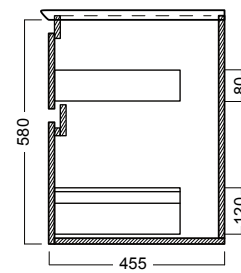

Top Section

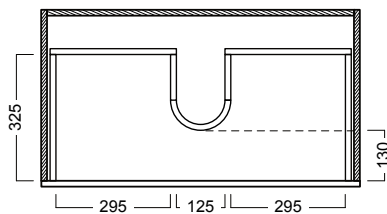

Notes

Sizes approximate. All drawings in millimeters. Drawings not to scale.

Drawing indicates the technical measurement only and is not a reflection of how the unit will look.