

# WAIPORI BASIN MIXER INSTALLATION GUIDE

## TECHNICAL SPECIFICATIONS

### Operating Pressure:

Min 35kPa, Max 1000kPa.

Recommended 35kPa - 500kPa.

Recommended installation of a pressure limiting valve if supply exceeds 500kPa.

### Operating Temperature:

Hot: Max 80°C.

Cold: Min 5°C.

NB: New Zealand Building Code Clause G12 - Water Supplies specifies all outlets used primarily for personal hygiene shall deliver water at a safe temperature.

### Inlet Connections:

All 1/2" BSP.

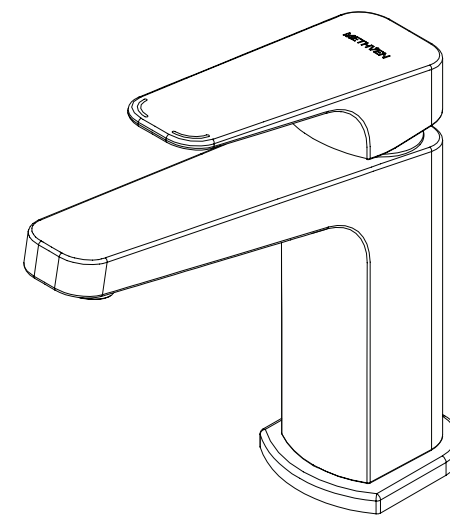

Methven warrants this product against manufacturing defects and that it is suitable for use under the operating conditions specified in this instruction sheet.

For your warranty please refer to [www.methven.com](http://www.methven.com) or call Customer Service

New Zealand  
0800 804 222

Australia  
1300 638 483

UK  
0800 195 1602

436700

Issue C



# IMPORTANT

Please read all of the instructions before installation

This mixer is designed for equal and unequal pressure systems.

All pipework must be thoroughly flushed prior to the installation of the mixer. In-line filters must be fitted on both hot and cold supplies to prevent foreign particles damaging the ceramic cartridge.

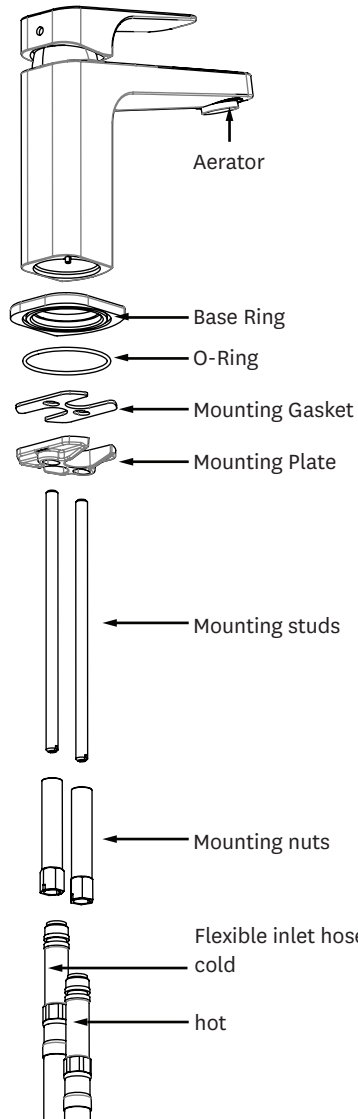

## Equal Low Pressure and Unequal Pressure Installations

Remove flow restricted (yellow) aerator using cache key.  
Replace with un-restricted (white) aerator

## Unequal pressure installations

Install flow restricted brass nipple on cold inlet

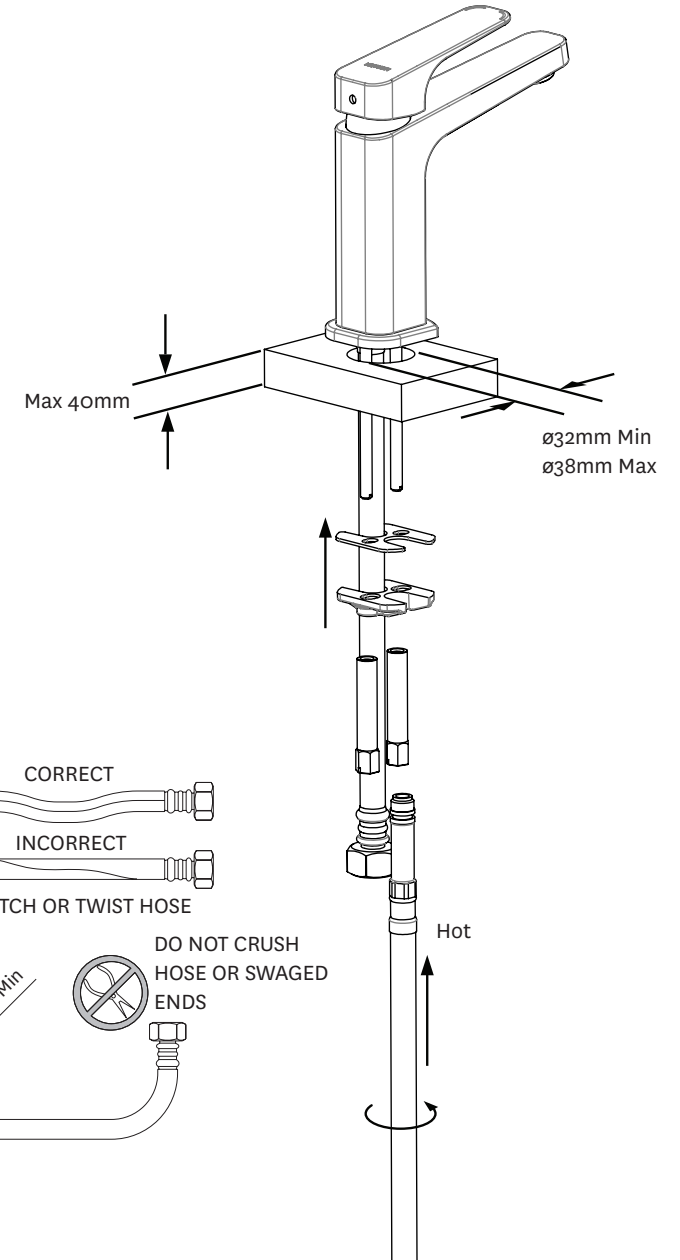
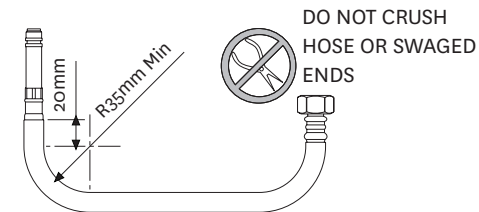
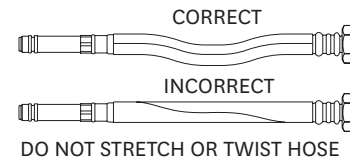
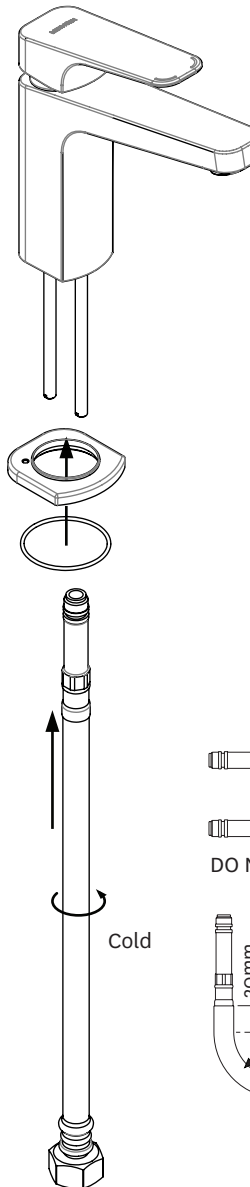
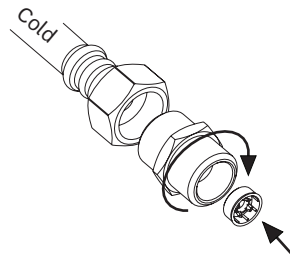

TIP - Install product to mounting surface before connecting second hose to mixer.